

33.3 kW Modular Power Unit for EVSE



OVERVIEW

MPU-R2 is a 33.3 kW modular power supply for EVSE systems. It features a modular design capable of parallel operation.

FEATURES

- AC connection to standard 400/480 VAC, 50/60 Hz grid. No neutral required.
- Reinforced galvanic isolation between input and output.
- Capable of charging 400V and 800V batteries.
- Integrated forced air cooling with fan speed control.
- 19" rack, 2U
- CANopen compatible digital bus with advanced control, monitoring and logging capabilities.
- Integrated protections including AC pre-charge switches, OCP, OTP and UVLO.
- Integrated output fuse and reverse diode.

VERSIONS

	P	Udc	Idc	Comments
MPU-R2-920-100-FD	33.3kW	920V	100A	
MPU-R2-920-100-FD-UL	30kW	920V	100A	UL2202 certified (E537398)

BLOCK DIAGRAM

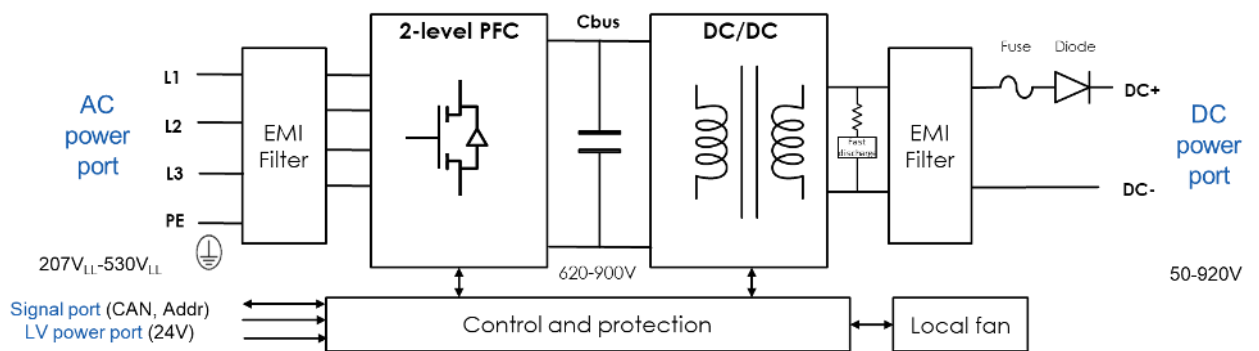

TABLE OF CONTENTS

1.	Safety instructions	5
1.1.	Caution	5
1.2.	Installation.....	5
1.3.	Input rating	5
1.4.	Live circuits.....	5
1.5.	Hot surface.....	5
1.6.	Touch current.....	6
1.7.	Marking	6
1.8.	Maintenance.....	7
1.9.	Safety related functions.....	7
1.10.	Parts substitution and modifications.....	7
1.11.	Environmental condition	7
1.12.	Normative compliance.....	8
2.	Moving and storage instruction	9
3.	Environmental characteristics	10
4.	Reliability characteristics	10
5.	Electrical Characteristics.....	11
5.1.	Earthing system compatibility	12
5.2.	Safe Operating Area	13
5.3.	Typical efficiency.....	14
5.4.	Output power derating.....	14
6.	Installation	17
6.1.	Mechanical installation	17
6.1.1.	<i>Handling</i>	17
6.1.2.	<i>Mounting</i>	17
6.2.	Electrical installation.....	18
6.2.1.	<i>Legal installation</i>	18
6.2.2.	<i>Safety Notice</i>	18
6.2.3.	<i>Protective earth</i>	18
6.2.4.	<i>AC input</i>	19
6.2.5.	<i>LV DC input</i>	19
6.2.6.	<i>DC Output</i>	19
6.2.7.	<i>EMI requirements</i>	20
6.2.8.	<i>Series operation</i>	20
6.3.	Disposal	20
7.	Hardware specification	21
7.1.	Theory of operation	21
7.2.	Interfaces and supply cables.....	22

7.2.1.	<i>Low voltage connector</i>	22
7.2.2.	<i>AC side connector</i>	23
7.2.3.	<i>DC side connectors</i>	24
7.2.4.	<i>COM connector</i>	25
7.2.5.	<i>Emergency Shutdown</i>	26
7.2.6.	<i>Address selector and Charge Permission</i>	26
7.2.7.	<i>Protective Earth</i>	29
8.	Control specifications	30
8.1.	Theory of operation	30
8.2.	User inputs	30
8.3.	User outputs	33
8.4.	Protection features	33
8.5.	CAN communication	35
8.5.1.	<i>CAN transceiver</i>	35
8.5.2.	<i>CAN configuration and dictionary</i>	35
9.	Mechanical specifications	42
10.	Maintenance	42
10.1.	Cleaning	42
10.2.	Cooling fan	42
10.3.	Fuse replacement	42
11.	Ordering information	43
11.1.	Product Reference	43
11.2.	Product accessories	43
11.3.	Related products	45



WARNING

This equipment operates at voltages and currents that can result in electrical shock, fire hazard and/or personal injury if not properly handled or applied. Equipment must be used with necessary caution and appropriate safeguards employed to avoid personal injury or property damage.

This board must be used only by qualified engineers and technicians familiar with risks associated with handling high voltage electrical and mechanical components, systems, and subsystems.

1. Safety instructions

IMPORTANT SAFETY INSTRUCTIONS

SAVE THESE INSTRUCTIONS – This manual contains important instructions for Models **MPU-R2-920-100** that shall be followed during installation, operation and maintenance of the unit.

1.1. Caution

The following safety instruction must be observed during all phases of operation, service and repair of this equipment. Failure to comply with the safety precautions or warnings in this documentation violates safety standards of design, manufacture and intended use of this equipment and may impair the built-in protections within. WATT & WELL shall not be liable for users to comply with these requirements.

1.2. Installation

MPU-R2 device must be installed following installation chapter.

This product is a safety **Class 1** instrument. To minimize shock hazard, the instrument chassis must be connected to the EVSE frame which is in turn is connected to earth ground

The protective earth terminal must be connected to the safety electrical ground before another connection is made. Any interruption of the protective ground conductor, or disconnection of the protective earth terminal will cause a potential shock hazard that might cause personal injury.

MPU-R2 device is designed to be accessible only for trained staff operators in **restricted access locations**.

1.3. Input rating

CAUTION – To reduce the risk of fire, connect only to a circuit provided with 63 amperes maximum branch circuit overcurrent protection in accordance with the National Electrical Code, ANSI/NFPA 70.

Do not use power supplies which exceed the input voltage rating of this instrument. The electrical rating of this instrument is given into the chapter 5 of this document.

1.4. Live circuits

Operating personnel are not allowed to open the case of this equipment. Internal adjustment or component replacement is not allowed by non-WATT & WELL qualified personnel. Never replace components with cable connected to this instrument. To avoid injuries, always disconnect power and remove external voltage sources before touching components.

1.5. Hot surface

Surface of the product could be hot during and after operation.

To reduce the risk of burns – Do not touch or use adequate protection before touching the device.





1.6. Touch current

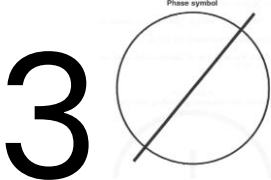

CAUTION: A touch current > 3.5 mA AC RMS is possible in case of a fault condition of loss of electrical continuity of the earthing conductor in IT earthing systems.

The minimum size of the protective earthing conductor shall comply with the local safety regulations.

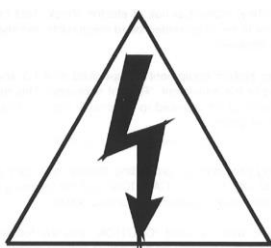
1.7. Marking

Symbol	English	French
	Input alternating current	Courant d'entrée alternatif
	Number of phases input phase	Nombre de phase AC
	Grounding	Prise de Terre
	<p>CAUTION - Risk of electric shocks</p> <p>Capacitor stores hazardous energy.</p> <p>Do not remove cover until 5 minutes after disconnecting all sources of supply.</p>	<p>ATTENTION - Risque de choc électrique.</p> <p>Le condensateur accumule de l'énergie dangereuse.</p> <p>Ne pas retirer le couvercle jusqu'à 5 minutes après le débranchement de toutes les sources d'alimentation.</p>
	<p>CAUTION- HOT SURFACES</p> <p>To reduce the risk of burns - Do not touch</p>	<p>ATTENTION - SURFACES CHAUDES</p> <p>Pour réduire le risque de brûlures - Ne pas toucher</p>

1.8. Maintenance

Capacitors inside the unit store hazardous energy. Do not remove the cover until 5 minutes after disconnecting all sources of supply.

1.9. Safety related functions

All safety related mechanisms and functions are implemented by hardware. The software does not provide or perform safety-related functions.

1.10. Parts substitution and modifications

Parts substitutions and modifications are allowed by authorized WATT & WELL service personnel only.

For repairs or modification, the unit must be returned to WATT & WELL's After Sale Service. Contact After Sale Service (aftersales@wattandwell.com) to obtain a return merchandise authorization (RMA) number.

WATT & WELL
After Sale Service
121 Rue Louis Lumière
84120 PERTUIS
France

1.11. Environmental condition

MPU-R2 device safety approval applies to the following operating conditions:

- Integrated into EVSE system (in a 19" cabinet or a custom build enclosure)
- Maximum relative humidity : 95% at 40°C non-condensing
- Altitude : up to 2000m
- Pollution degree : 2
- Overvoltage category : III on AC side
- IP degree of enclosure : IP2X



Protective ground conductor terminal

The charging station where MPU-R2 will be installed should meet the requirements of environmental protection as defined in IEC 61851-1:2019.

The IP degree needs to reach IP44 or above for outdoor use or IP21 for indoor use.

Avoid using the charger in the offshore environment near the sea or near a pollution source or in a corrosive and damaging environment. If you need to use it in the above environment, the protection level of the station needs to reach IP65, otherwise it may lead to the failure of MPU-R2. This damage caused will not be covered by the warranty.

1.12. Normative compliance



MPU-R2 versions **VI.0.1 and forward** meet the intent of directives:

- CEM 2014/30/UE
 - NF EN IEC 61000-6-1: Electromagnetic compatibility (EMC) Part 6-1: Generic standards – Immunity standard for residential, commercial and light-industrial environments
 - NF EN IEC 61000-6-2: Electromagnetic compatibility (EMC) Part 6-2: Generic standards – Immunity standard for industrial environments
 - NF EN IEC 61000-6-3: Electromagnetic compatibility (EMC) Part 6-3: Generic standards – Emission standard for equipment in residential environments
 - NF EN IEC 61000-6-4: Electromagnetic compatibility (EMC) Part 6-4: Generic standards – Emission standard for industrial environments
- RoHS: 2011/65/UE
- WEEE: 2012/19/EU

Please also note that MPU-R2 is designed to be compatible with the following standards:

Normative	Name	Note
IEC 61851-1:2019 (ed 3.0)	Electric vehicle conductive charging system Part 1: General requirements	
IEC 61851-23:2023 (ed 2.0)	Electric vehicle conductive charging system Part 23: DC electric vehicle charging station	
UL 2202	UL Standard for Safety DC Charging Equipment for Electric Vehicles	With version MPU-R2-920-100-FD-UL

However, it is the user's responsibility to ensure that MPU-R2 is installed and used in compliance with all local country laws and regulations.

2. Moving and storage instruction

To ensure the safe handling and storage of the converter and to prevent risks of fire, electric shock, or injury to persons during subsequent use, please follow these instructions carefully:

Moving the Unit:

- Before moving the converter, ensure it is powered off and disconnected from all electrical connections.
- Use proper lifting techniques and equipment to handle the weight of the unit.
- Avoid dropping, tipping, or applying excessive force to the unit during movement. Sudden impacts can damage internal components, potentially leading to safety hazards.
- Protect the unit from exposure to moisture, dust, and extreme temperatures during transportation.
- Use the original packaging or equivalent protective materials to minimize the risk of physical damage.

Storage Guidelines:

- Store the converter in a clean, dry, and well-ventilated area.
- Avoid environments with high humidity or exposure to corrosive chemicals.
- Maintain the storage temperature within the range specified in the technical specifications of this manual
- Ensure the unit is stored in its upright position.

Inspection Before Reuse:

- Before reusing the unit after storage, inspect it for visible damage, including cracks, corrosion, or loose connections.
- Check all electrical terminals and connections for signs of damage or wear. Tighten any loose connections as per the installation guidelines.
- If any damage is observed, do not power on the unit. Contact a qualified technician or the manufacturer for further assistance.

3. Environmental characteristics

Table 1: Environmental characteristics

Parameter	Index
Operating Temperature	-30°C ~ +70°C Recommended maximum ambient temperature is 50°C. See chapter 5.4 for derating curves.
Long term storage Temperature	-30°C ~ +70°C
Relative humidity	5% RH ~ 95% RH (No condensation)
Altitude	up to 2000m (above 2000m above sea level, derating is required)
Pollution degree	2 ^{Note 2}
Overvoltage category	III on AC grid side
Acoustic noise	≤70dB (25°C, 400V input, rated output full load)

4. Reliability characteristics

Table 2: Reliability characteristics

Parameter	Conditions	Value			Units
		Min	Typ	Max	
MTBF	Ambient temperature 40°C Fans replaced after 7 years		500,000		hours

² Attention should be paid to avoid ingress of water, metallic or conductive particles, dust or corrosive atmospheric that may cause early failures of equipment.
Consult factory if pollution degree 3 is required.

5. Electrical Characteristics

Table 3: Absolute maximum ratings

Parameter	Condition	Min	Max	Units
LV Input Voltage		0	26	V
DC side voltage		0	1000	V
AC side voltage (phase-phase)			530	V _{RMS}
DC output (DC+ or DC-) to PE			±1000	V

All specifications are given for ambient temperature up to 50°C unless otherwise noted.

Table 4: Electrical characteristics

Parameter	Condition	Value			Units
		Min	Typ	Max	
AC side					
Voltage (phase-phase)		176	400 or 480	530	V _{RMS}
Voltage (phase-neutral)		102	230 or 277	305	V _{RMS}
Current (per phase)		0		46 ³ 51 ⁴	A _{RMS}
AC Inrush current				42.4	A _{pk}
Input frequency		42.5	50	69	Hz
Current measurement accuracy	@46Arms			3	%
Voltage measurement accuracy	@400V _{LL}			3	%
Power factor			0.99		
Current THD at full power			2.5	3	%
Current THD at 50% power			3	4	%
Standby Active Power Consumption				10.5	W
Standby Reactive Power Consumption				760	VAR
DC side					
Voltage		200		920	V _{DC}
Power				30 ³ 33.3 ⁴	kW
Maximum power variation (SW programmable)	Active power			30	kW/s
Current				100	A
Voltage measurement accuracy	@920V			0.5	%
Current measurement accuracy	@50A _{dc}			1.5	%
CAN communication					
CAN baud rate			500		kbps

³ With MPU-R2-920-100-FD-UL version

⁴ With MPU-R2-920-100-FD version V1.1.0 and above.

CAN common mode range ⁵		-7		7	V
Digital Inputs					
Positive going input current (Charge permission, Address, EMS)		2		10	mA
Negative going input current (Charge permission, Address, EMS)				0.1	mA
Maximum reverse voltage				5.5	V
LV input					
Supply voltage		19	24	26	V
Input current standby			0.2		A
Input current operation	Fan ON (full speed)		2.5	3	A
Input current start-up (inrush)	@24V input during 1ms			30	A
Under Voltage Shutdown				16	V
Over Voltage Shutdown				30	V
Power consumption		7 ⁶	60	75 ⁷	W
Insulation					
Input (AC) to output (DC)	50/60 Hz, 1 min	3400			V _{RMS}
Input (AC) to case (PE)	50/60 Hz, 1 min	3400			V _{RMS}
Output (DC) to case (PE)	50/60 Hz, 1 min	3400			V _{RMS}
Y-capacitor DC+ to PE or DC- to PE				35	nF

5.1. Earthing system compatibility

The charger is compatible with TT, TN and IT earthing systems.

⁵ CAN common mode; CAN_H and CAN_L versus CAN_GND

⁶ Standby mode operation

⁷ Three-phase charging with fans at full speed and 26V input voltage

5.2. Safe Operating Area

MPU-R2 automatically adjusts its operation to the typical operating zone of an EV battery and can charge 400V and 800V nominal EV batteries.

The Safe Operating Area (SOA) are shown in Figure 1 and Figure 2 for CE and UL versions respectively.

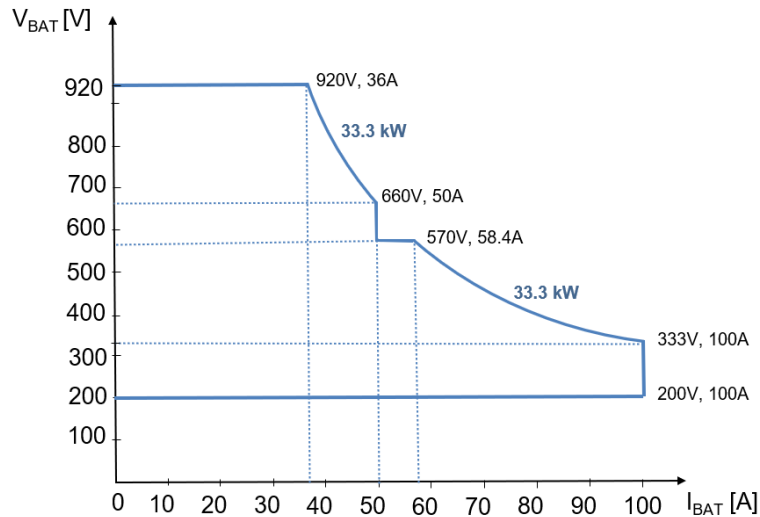

Figure 1: Battery Side Safe Operating Area under grid conditions 400V/50Hz at 25°C of MPU-R2-920-100-FD with Versions 1.1.0 and forward

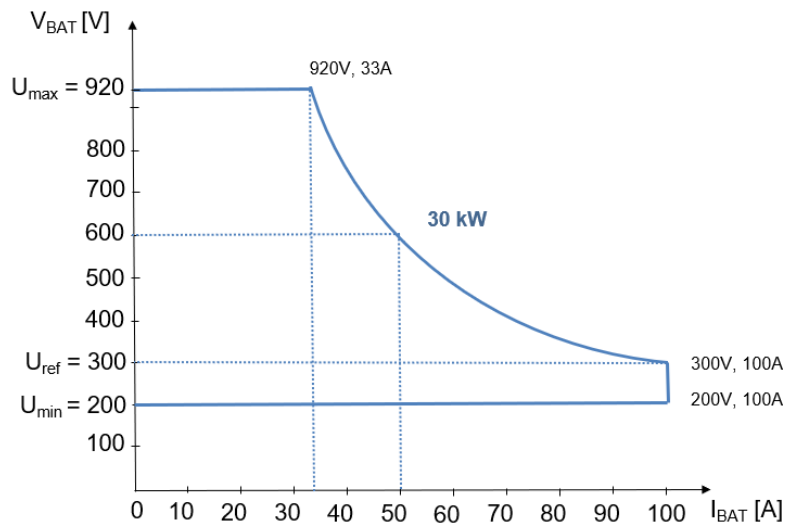

Figure 2: Battery Side Safe Operating Area under grid conditions 400V/50Hz at 25°C of MPU-R2-920-100-FD-UL version

5.3. Typical efficiency

MPU-R2 is based on highly efficient full SiC (Silicon Carbide) technology. Peak efficiency reaches more than 96% and efficiency is consistently above 94% for a wide range of battery voltage and current.

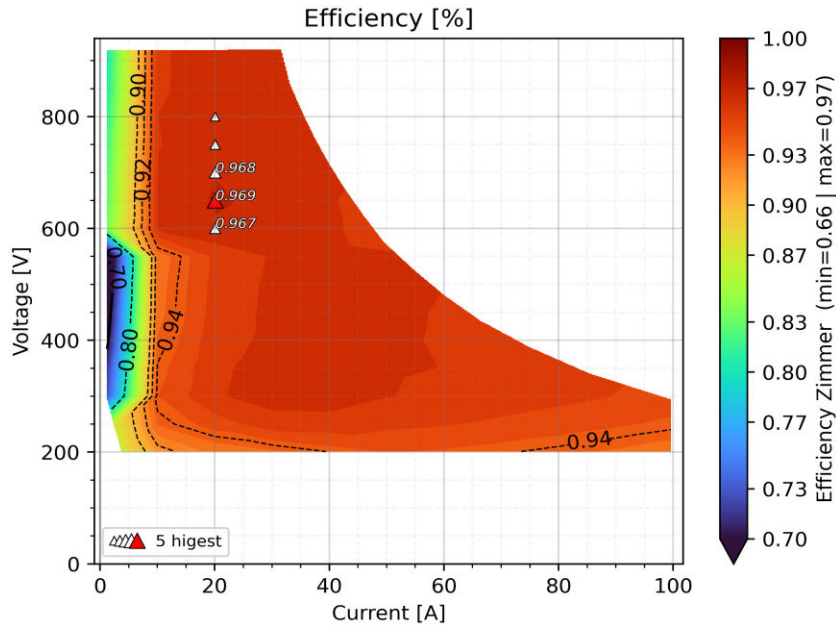

Figure 3: Typical efficiency in three-phase mode under grid conditions 400V/50Hz at 25°C

5.4. Output power derating

For MPU-R2-920-100-FD-UL version derating on the power output is applied above 40°C ambient temperature as shown below.

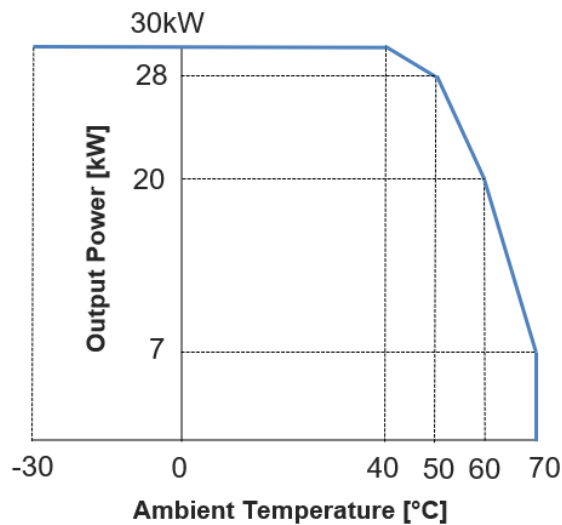

Figure 4: output power derating in function of the ambient temperature for MPU-R2-920-100-FD-UL version

For MPU-R2-920-100-FD non UL version, 33.3kW power can be reached on most operating points at 25°C ambient temperature (see figure 1). The converter is thermally designed for 30kW operations : depending on the battery voltage, a derating can apply in steady state (~10 min) above this 25°C ambient temperature (see figure 6) .

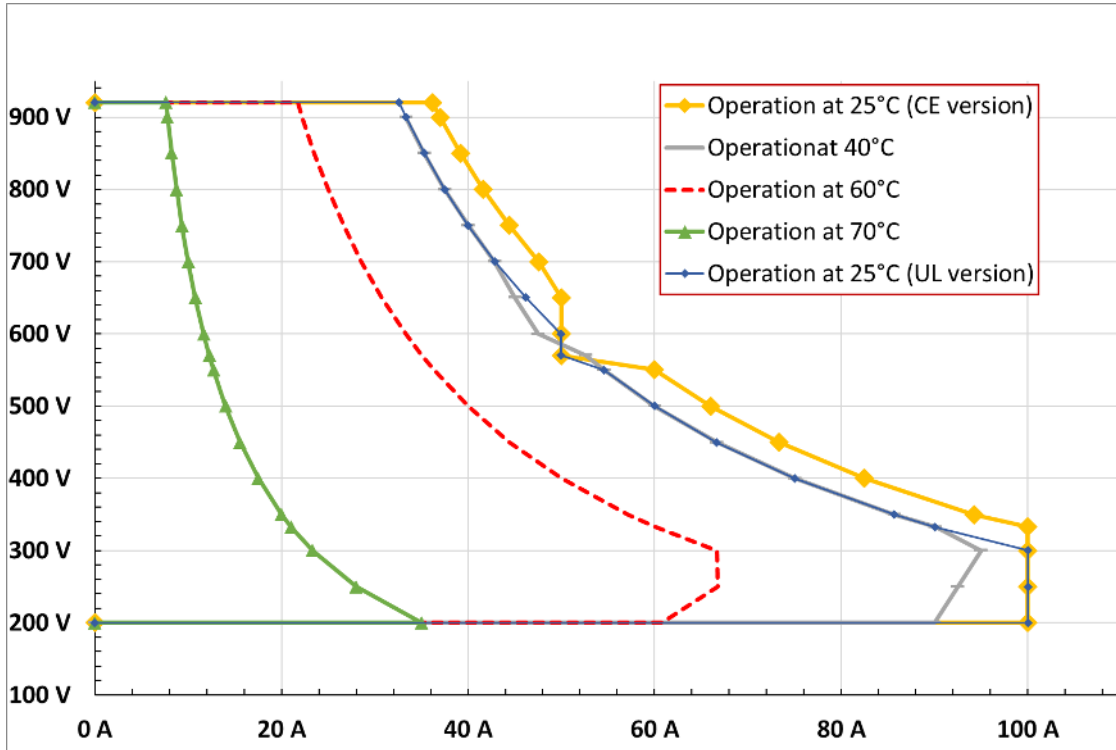

Figure 5: detailed safe operating area in function of the ambient temperature for HW V1.1.0 and forward

For V1.1.0 version of MPU-R2-920-100-FD the converter is sized for 35.5kVA (AC side power) at 230V (line to neutral)

- Below 230V, power is limited by max current 51 Arms
- Above 230V, power can be kept constant

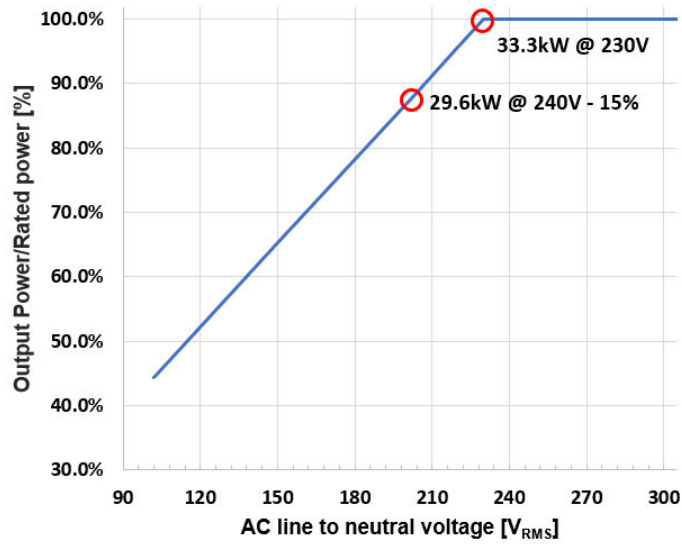

Figure 6: Output power vs AC line voltage (phase-neutral)

6. Installation

The unit must be properly assembled in accordance with the assembly instructions before it is used.

Do not use or install MPU-R2 product in case of visible physical damage.

MPU-R2 should be installed in EVSE that complies with frame and enclosure requirement of UL2202.

6.1. Mechanical installation

6.1.1. Handling

MPU-R2 product has a weight of about 22 Kg. For correct handling, follow instruction below:

- The product must be handled flat.
- For operator safety use personal protective equipment.
- Do not stack units (each unit should be self-supported and secured with the front and rear brackets)

6.1.2. Mounting

MPU-R2 can be mounted on standard 19" cabinets.

Note that the MPU-R2 is a heavy instrument and requires the cabinet to be equipped with slides or rails that provide full-depth support for the chassis.

To ensure proper airflow and prevent heat accumulation, mounting the MPU-R2 with the fans facing upward is not permitted, as fans are designed to blow air rather than extract it.

Additionally, mounting the MPU-R2 with the top cover facing downward is prohibited, as it increases mechanical stress on internal components.

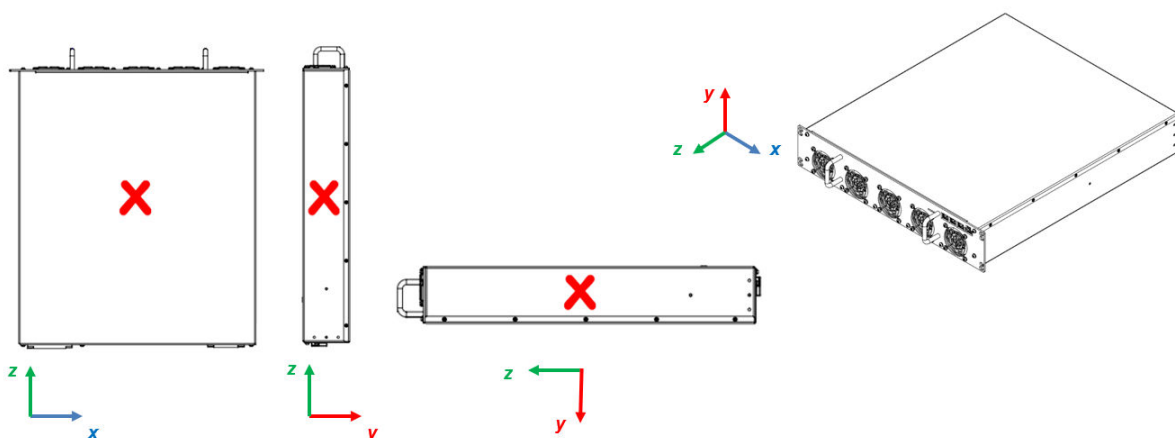

Figure 7: not allowed rack mounting positions

Minimum air flow required for air cooling is 5.6 m³/min (200 CFM) and the ventilation path should be free of obstructions.

Recirculating of hot air should be minimized by ensuring fresh (cold) on the input (see Figure 8). In addition, minimum distances for air cooling are:

- 15 cm for front side
- 9 cm for rear side

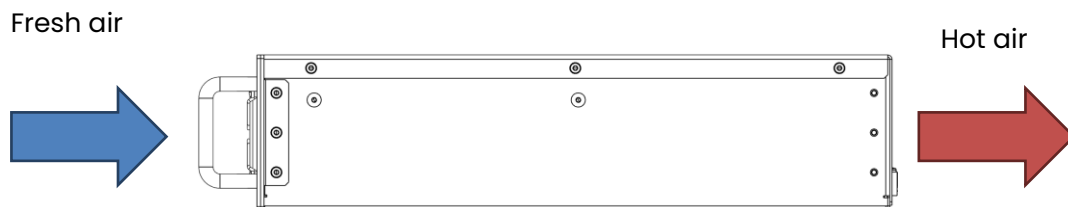

Figure 8: Air flow direction

6.2. Electrical installation

6.2.1. Legal installation

Electrical installation shall comply with international standards such as IEC or the requirements in national standards of each country.

6.2.2. Safety Notice

Never invert the polarity of the connector. Never force to place a connector. Use only approved manufacturer parts for electrical or mechanical connection.

It is strongly recommended to fix the cables to avoid any stress on the connection. All high-power connectors must be securely fastened to avoid any disconnection.

Be careful if other devices are connected, there is a risk of electrical charge transfer.

It is forbidden to open the cover. Only W&W approved personnel are allowed to do maintenance operation. waiting time after complete suppression of input voltage before opening the device should be respected.

6.2.3. Protective earth

MPUR2 should be referenced to the EVSE frame which is in turn is connected to earth ground.

Protective earth connection is made through AC input connector.

In addition, all parts of the chassis where MPU-R2 is to be installed (i.e., the 19" cabinet) need to be grounded. An electrical connection to "G" through mechanical parts must be done.

The protective earthing conductor and the protective conductor shall be green/yellow striped color with a cross section equal to the cross section of the phase conductors (16mm²).

MPUR2 is allowed to be operated by an ordinary person if MPUR2, when installed, is connected to a supply network that provides a protective earthing conductor.

Any interruption of the protective ground conductor, or disconnection of the protective earth terminal could cause a shock hazard that might cause personal injury or death.

MPUR2 is only allowed to be operated by skilled personnel or instructed personnel if MPUR2, when installed, is connected to a supply network that does not provide a protective conductor or a protective conductor that is not earthed.

6.2.4. AC input

AC input is defined as three phases line without neutral.

MPU-R2 product must be protected against short circuit, overload protection and earth leakage current protection with external devices.

An overvoltage protective circuit that consists of a combination of varistors "S20K320" and surge arrester B88069X4231 is included on the AC input side of the charger. This circuit protects the charger from power surges and voltage transients.

AC input wires must be connected through an overcurrent protection device in the end product.

For European countries, we recommend using a residual current breaker/device (RCB/RCD) and a circuit breaker (MCB) with short circuit protection and thermal overload protection:

- Class B recommended. Class A is also possible since all grid inputs are double isolated from PE.
- Earth leakage 30mA (lower rating also possible, please consult factory)
- Current rating 63 A
- Number of contacts: 3 or 4

6.2.5. LV DC input

LV input must be connected to a class II AC/DC converter with 24V nominal output voltage (limited to 26Vdc max) and 100 W of output power.

This input must integrate a short circuit protection either integrated on the output of the AC/DC converter or via an external fuse of adequate rating.

This cable must be shorter than 3m.

6.2.6. DC Output

DC output is galvanically isolated from protective earth.

This cable must be shorter than 30m.

6.2.7. EMI requirements

MPU-R2 versions **V1.0.1 and forward** are compliant with IEC 61000-6-2 (immunity standard for industrial environment – class A) and IEC 61000-6-3 (emission standard residential environment – class B) with the additions of:

- 2 turns ferrite FAIR-RITE 0431177081 on AC input port,
- 2 turns ferrite FAIR-RITE 0431177081 on DC input port,
- 2 turns ferrite 742 712 22S on CAN communication port,
- 3 turns ferrite 742 712 22S on LV input port.

6.2.8. Series operation

Series operations of MPU-R2 is not allowed.

6.3. Disposal



(Mandatory application within the European Union)

Do not dispose of electronic tools together with household waste material. In accordance with WEEE European Directive (2012/19/UE), Electric material that has reached the end of their life must be collected separately and return to an environmentally compatible recycling facility.

Please contact WATT & WELL for any questions about WEEE.

7. Hardware specification

7.1. Theory of operation

MPU-R2 consist of 2 power converting stages:

- Bidirectional Active Front End (or PFC) that interfaces the AC grid. This PFC uses a three-phase topology
- DC/DC converter that performs galvanic isolation and DC side regulation. It is based on a full SiC resonant topology

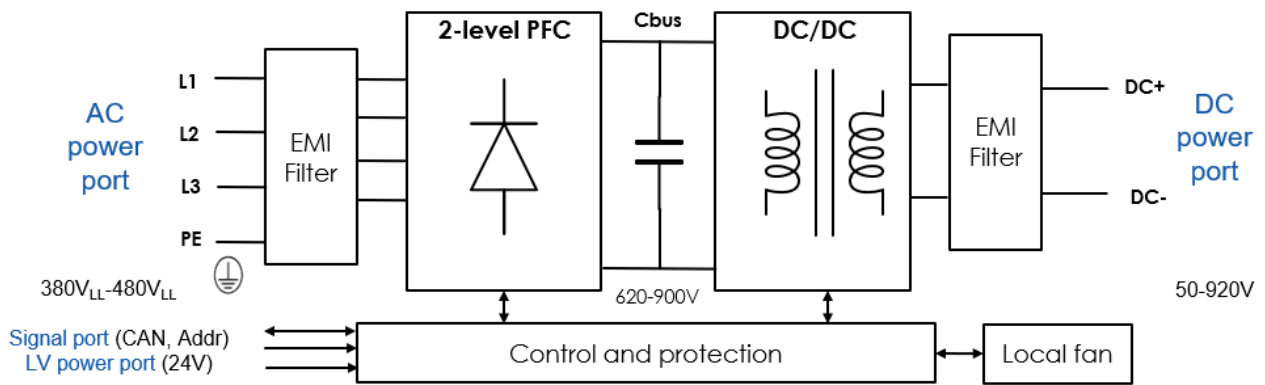

Figure 9: MPU-R2 30 kW high level synoptic

7.2. Interfaces and supply cables

Please note that the supply cables of the converter shall be chosen to have an ampacity based on Table 310-16 of the National Electrical Code, ANSI/NFPA 70 of no less than 125 percent of the maximum current that the circuit carries during rated conditions; and that a wiring terminal are provided with a pressure terminal connector that is securely held by a screw.

7.2.1. Low voltage connector

Located on the front panel. Cable connected to these ports must be less than 3m long. The LV connector is used to power the fans and control independently the converter.

The interlock has a screw locking mechanism. Use a 3mm flat head screwdriver with a tightening torque of 0.3 N.m.

For securing all conductors use a 3mm flat head screwdriver with a tightening torque of 0.5 N.m.

Connector Reference (converter side):

- Phoenix Contact MSTB 2,5/ 2-GF-5,08 1776508 (UL approval 300V/15A)
- TIELEE: TLPHW-200R-02P-G12 (UL approval 300V/16A)

Recommended mating connectors (wire harness side):

Side	Connector	Manufacturer	Wire	Ferrule	Crimping tool
LV	MSTB 2,5/ 2-STF-5,08 – 1777989 (Screw terminal)	Phoenix contact	1 mm ²	A 1-6 Ref 3200247	Phoenix Contact 1212034 CRIMPFOX 6
LV	TLPSW-200V-02P-G12S	TIELEE	1 mm ²	A 1-6 Ref 3200247	Phoenix Contact 1212034 CRIMPFOX 6

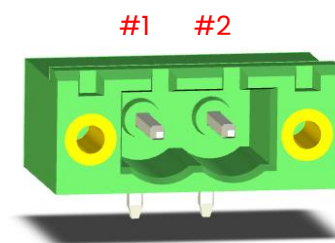

Figure 10: LV IN connector

PIN	FUNCTION	DESCRIPTION	Preferred wiring color
#1	LV_IN-	Low Voltage supply return (0V typ)	Black
#2	LV_IN+	Low Voltage supply (24V typ)	Red

7.2.2. AC side connector

Located on the back panel of the rack.

The interlock has a screw locking mechanism. Use a T20 torx head screwdriver with a tightening torque of 0.8 N.m.

For securing all conductors use a T20 Torx screwdriver with a tightening torque of 2.5 N.m.

Connector Reference (converter side):

- Phoenix Contact: PC 35 HC/4-GF-15,00-1762767 (UL approval 600V/115A)

or

- TIELEE: TLPHW-900R-A394-04P-G17 (UL approval 600V/115A)

Recommended mating connectors (wire harness side):

Side	Connector	Manufacturer	Wire	Ferrule	Crimping tool
AC	PC 35 HC/ 4-STF-15,00 Ref: 1762615	Phoenix contact	16 mm ²	A 16 -25 Ref 1090632	Phoenix Contact CRIMPFOX 25R Ref 1212039
AC	TLPSW-900V-A394-04P- G12C	TIELEE	16 mm ²	CNI60018	Phoenix Contact CRIMPFOX 25R Ref 1212039

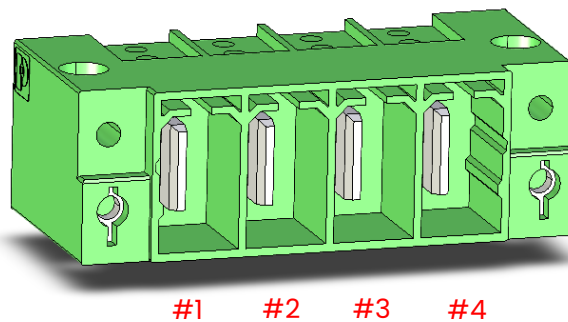

Figure 11: AC IN connector

PIN	FUNCTION	DESCRIPTION	Preferred wiring color
#1	L1	Mains line 1	Brown
#2	L2	Mains line 2	Black
#3	L3	Mains line 3	Grey
#4	PE	Protective Earth	Green/yellow striped

7.2.3. DC side connectors

Located on the back panel of the rack. Cable connected to these ports must be less than 30m long.

The interlock has a screw locking mechanism. Use a T20 torx head screwdriver with a tightening torque of 0.8 N.m.

For securing all conductors use a T20 torx head screwdriver with a tightening torque of 4.5 N.m.

Connector Reference (converter side):

- Phoenix Contact: PC 35 HC/ 3-GF-15,00 BK – 1762754 (UL approval 600V/115A: middle pin left NC)
- TIELEE: TLPHW-900R-A425-02P(G17) (3 pins connector with pin removed. UL approval 115A)

Recommended mating connectors (wire harness side):

Side	Connector	Manufacturer	Wire	Ferrule	Crimping tool
DC	PC 35 HC/ 3-STF-15,00 Ref: 1762602	Phoenix contact	35 mm ²	A 35 -20 Ref 3200409	Phoenix Contact CRIMPFOX 50R Ref 1212041
DC	TLPSW-900V-A425-02P(G12C)	TIELEE	35 mm ²	CN350018	Phoenix Contact CRIMPFOX 50R Ref 1212041

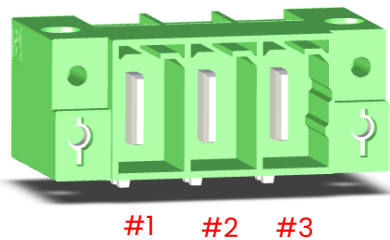

Figure 12: DC OUT connector

PIN	FUNCTION	DESCRIPTION	Preferred wiring color
#1	DC_OUT+	DC Output (positive)	Red
#2	NC	Not connected	
#3	DC_OUT-	DC Output return (0)	Black

7.2.4. COM connector

MPU-R2 features a galvanically isolated CAN bus for digital communications with other boards. The COM connector is an RJ45 connector located on the front panel. Cable connected to these ports must be less than 3m long.

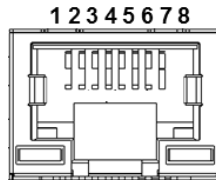

Figure 13 : COM connector front view

Table 5 – COM connector pinout

PIN	FUNCTION	DESCRIPTION
1	CAN H	CAN differential +
2	CAN L	CAN differential -
3	GND_ISO	Ground reference for CAN
4	EM_SHUT_RTN	Emergency Shutdown return line (negative)
5	EM_SHUT	Emergency Shutdown (positive)
6	NC	Not Connected
7	GND_ISO	Ground reference for CAN
8	ES_R/W	Read/write pin in case of daisy chained power units (Mandatory to keep floating)

Note on CAN bus termination: CAN bus is expected to be terminated at each bus end with a 120 Ω resistance. Wiring should be selected to have an intrinsic impedance of the twisted that match this 120 Ω.

By default, MPU-R2 does not include any 120 Ω resistor to avoid overloading the bus when multiple nodes are presents.

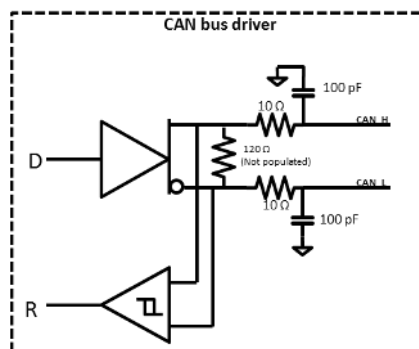

Figure 14: CAN transceiver simplified diagram

Note on CAN bus shield: Although ISO 11898-2 does not specify the wires type or the need for a shield, a shielded cable is recommended for electronically harsh environments. It is recommended to ground the shield at a single point on the dedicated shield pin of the COM connector to avoid ground loops.

Also, remember that the CAN bus being isolated, the CAN_GND should be wired between nodes.

7.2.5. Emergency Shutdown

The COM connector also transmits an **Emergency Shutdown** (EM_SHUT) signal. This signal can be used to trigger an unconditional shutdown of the MPU-R2 operation. See Table 5 for the pinout of EM_SHUT within the COM connector.

In addition, a fast discharge circuit is enabled to discharge the internal output capacitors to a safe level ($\ll 60V$) in less than 1 second.

EM_SHUT logic is as follows:

- “floating”: Emergency Shutdown triggered (EM_SHUT=1)
- 12V or 24V: normal operation (EM_SHUT=0)

The simplified circuit of the EM_SHUT is given in Figure 15.

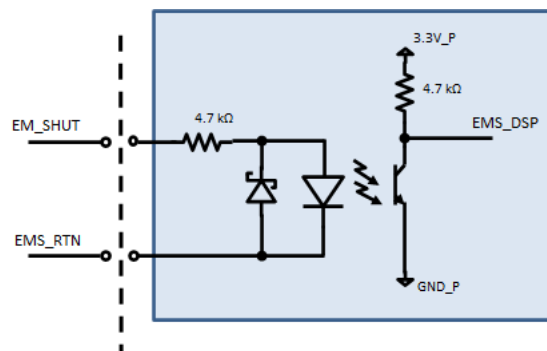

Figure 15 DSI input circuit

7.2.6. Address selector and Charge Permission.

Each MPU-R2 takes its CAN **address** at boot based on the Addressing connector on the front panel.

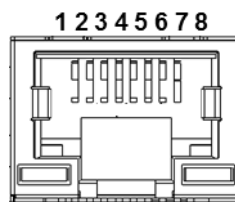

Figure 16: Addressing connector (RJ45) front view

Table 6: Addressing connector pinout

PIN	FUNCTION	DESCRIPTION
1	ADDR0	Address bit 0
2	ADDR3	Address bit 3
3	ADDR1	Address bit 1
4	ADDR4	Address bit 4
5	ADDR2	Address bit 2
6	GND_ISO	Return
7	CHARGE_P	Charge Permission
8	UNUSED	Not used

Default value of each unconnected/floating line is logic "0".
An addressing line tied to GND_ISO is logic "1".

Each MPU-R2 takes its CAN address at boot based on the Addressing connector on the front panel.

If ADDR0= ADDR1= ADDR2= ADDR3= ADDR4=0 → CAN ID=111 (default value)

Else

CAN ID = $80+2^0(\text{ADDR0})+2^1(\text{ADDR1}) +2^2(\text{ADDR2}) +2^3(\text{ADDR3}) +2^4(\text{ADDR4}) -1$

ADDR4	ADDR3	ADDR2	ADDR1	ADDR0	CAN ID (dec)
0	0	0	0	0	111
0	0	0	0	1	80
0	0	0	1	0	81
0	0	0	1	1	82
0	0	1	0	0	83
0	0	1	0	1	84
0	0	1	1	0	85
0	0	1	1	1	86
0	1	0	0	0	87
0	1	0	0	1	88
0	1	0	1	0	89
0	1	0	1	1	90
0	1	1	0	0	91
0	1	1	0	1	92
0	1	1	1	0	93
0	1	1	1	1	94
1	0	0	0	0	95
1	0	0	0	1	96
1	0	0	1	0	97
1	0	0	1	1	98
1	0	1	0	0	99
1	0	1	0	1	100
1	0	1	1	0	101
1	0	1	1	1	102

Please note that addresses having ADDR3 and ADDR4 tied to GND_ISO (ADDR3=ADDR4=1) are not acceptable.

For backward compatibility with MPU-R3-500-63-FD product, 14 units can be addressed using PWM signals with EVIX-AD14 (check Related products).

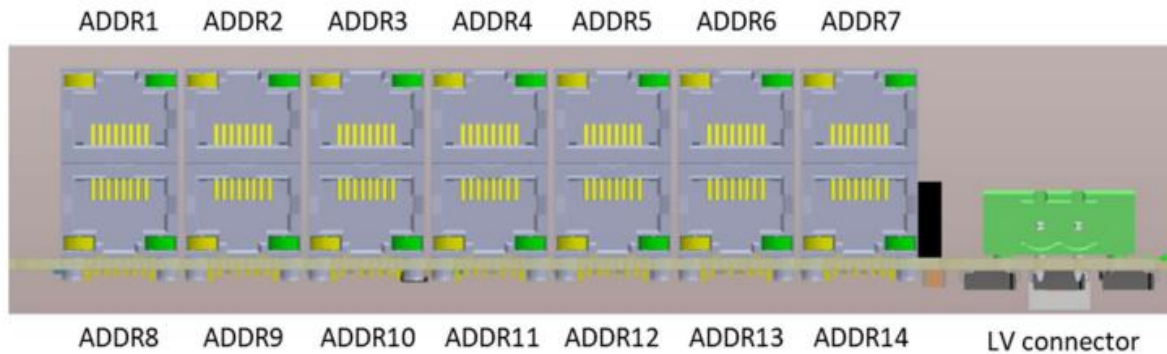

Figure 17: EVIX-AD14 board

“**Charge Permission**” signal: CHARGE_P2. This signal can be used as a redundant stop signal in such way MPU-R2 stops operation when it receives a stop instruction by either “Charge Permission signal” or “CAN communication message”. This functionality helps achieve compliance with safety features of some EV charging protocols like CHAdeMO. It is disabled by default.

When Charge Permission is enabled, logic levels are defined as

- ‘0’ or floating: no output (forbidden operation). If a start message is received by CAN, a fault will be generated.
- ‘1’ or shorted to GND_ISO: charge permission OK (system can start if a CAN message is received)

“**ES_R/W**” signal: should be kept floating by user on CAN connector side. It is used to disable the charging process of all units chained together in case of a fault on one unit.

LEDs

4 LEDs on front panel indicate the status of the system

Table 7: LED overview

LED	COLOR	FUNCTION	Description
1	Red	Fault	Indicates a fault in the system. System stops as a result
2	Green	Safe C	Blinking at 5Hz: Safe C mode. AC voltage is out of range. Output power is set off and the charger remains waiting for AC voltage to return within acceptable range
3	Green	DC output	Continuous: System in charge mode
4	Yellow or Orange	Voltage presence	Slow blink: Auxiliary voltage only (24V) Continuous: Grid voltage and Auxiliary voltage

7.2.7. Protective Earth

Protective Earth is connected through the AC input connector in the rear panel to the rack chassis.

8. Control specifications

8.1. Theory of operation

The control system of MPU-R2 consists of the following components:

- The overall behavior of MPU-R2 is governed by a state machine that defines the possible actions of the converter based on the user's state request.
- A PFC control system that regulates phase currents and DC bus voltage.
- A DCDC control system that regulates the battery-side current and voltage.
- Software protections against over/under-voltage, over/under-current, over-temperature, communication loss, etc.
- A fast discharge control for the DC output.
- CAN communication based on the CANopen protocol.
- Relay management, fan speed control, and LED lighting.

8.2. User inputs

MPU-R2 uses a fully digital, microcontroller-based regulator. This approach allows a very flexible control of the system. Figure 18 shows the regulation parameters that must be set through CAN messages to achieve the desired operating point. These parameters are defined as follows.

1. **State request:** The State Request word is used to request a state change. Three actions can be requested by the user as described in the following table:

State	Definition
Standby	System stopped and power off
Power On	System pre-charged and ready to start
Charging	Charge is ongoing

2. **AC current limitation:** limitation of AC currents
3. **DC current setpoint:** limitation of charging current
4. **DC voltage setpoint:** Battery side voltage target

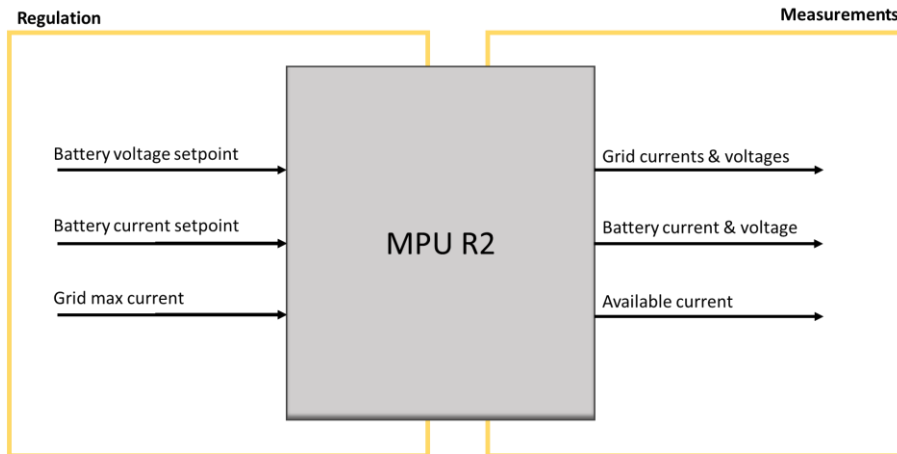

Figure 18: High level charger regulations and measurements

Battery current setpoint can be overridden by the system limitations as thermal derating, battery maximum power...etc.

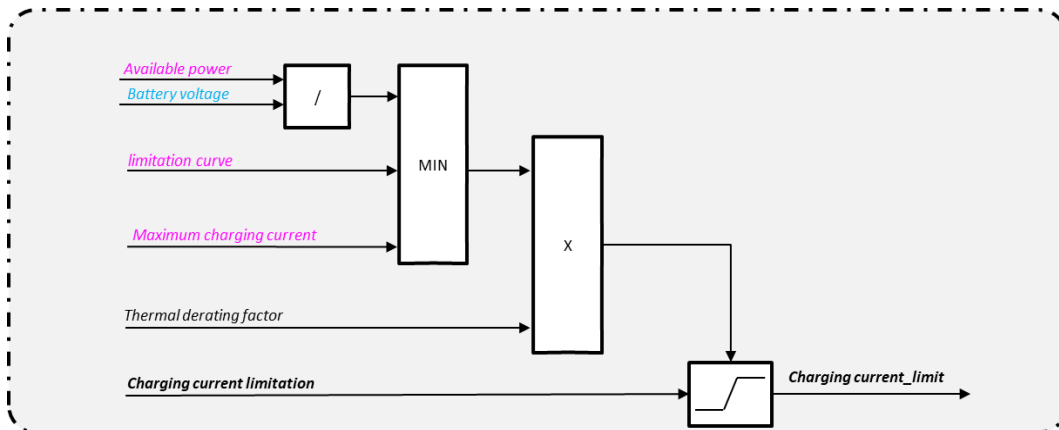

Figure 19: DC Charging current limitation

With

- **Charging current limitation:** the DC current setpoint requested by user
- **Maximum charging current:** set to 100A by default in parallel mode (up to ~570V battery voltage) and 50A in series mode (from ~570V battery voltage up to 920V)
- **limitation curve:** lookup table based on AC grid voltage
- **Available charging power:** it is calculated as follows.

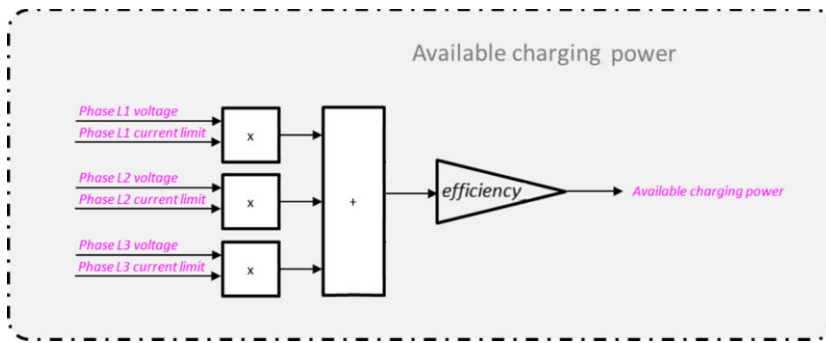

Figure 20: Available charging/discharging power

- thermal_derating_factor:** Thermal derating consists of derating delivered power linearly between derating start temperature threshold and shutdown temperature. The derating is applied by reducing the charging current by a thermal derating factor. This factor is the product of six factors driven from each type of temperature as shown in figure below. Thermal protection thresholds are defined based on component (mosfets, magnetics...etc) temperature specifications, experimental mapping, and sensors accuracy.

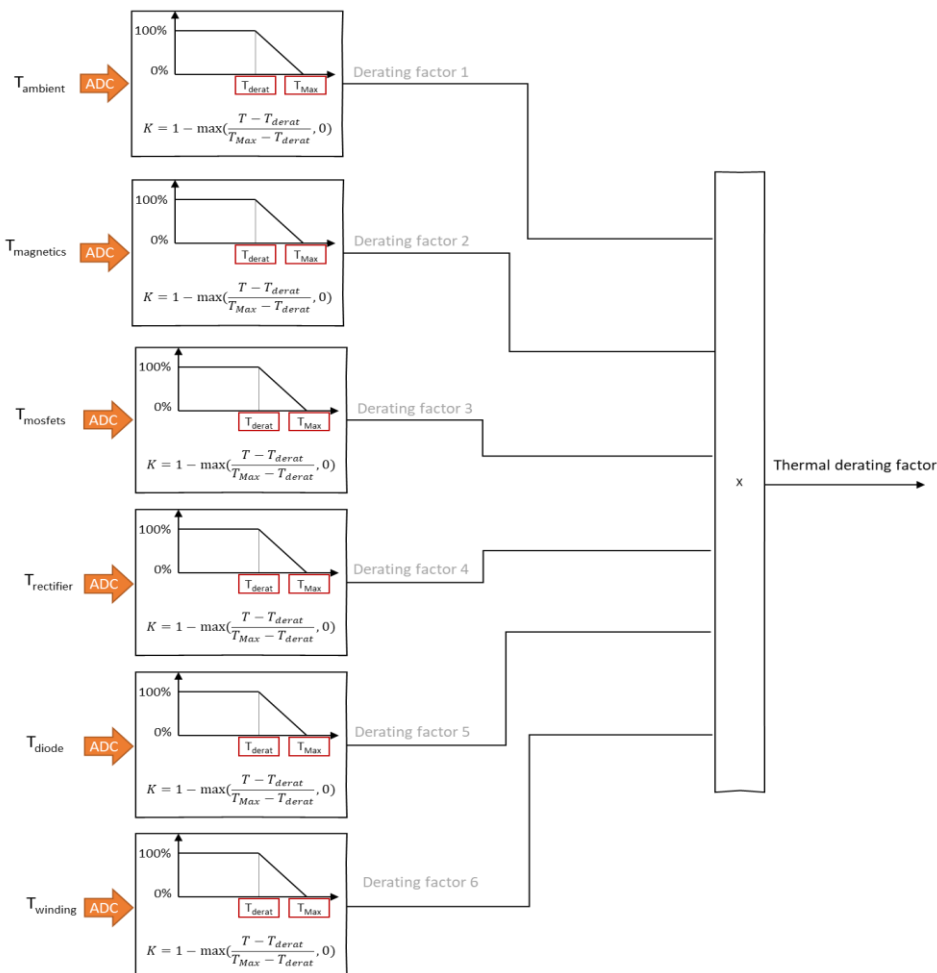

Figure 21: Thermal derating

Please note that changing the protection thresholds by the user is very risky and may result in the destruction of the product.

8.3. User outputs

The system returns measured current, voltage, active power for each phase. It also returns battery current, voltage, and power. A feedback is given on the system status and errors are reported in the fault word. Refer to Table 16 for details on fault word.

The status of the state machine is indicated in the System State bits within Status Word. Possible values are detailed in Table 11.

Available values of active power and DC current are returned by the converter. They are calculated based on AC voltage, battery voltage, thermal derating and user-defined maximum values. Refer to TPDOs list in 8.5.2.

8.4. Protection features

Feature	SW protection levels
AC Input Overvoltage Protection line to neutral	480V _{peak}
AC Input Undervoltage Protection line to neutral	96V _{rms}
DC Output Overvoltage Protection	1050V
Over temperature protection - T _{stop} ambient temperature	70
DC Overcurrent Protection	120A
AC Overcurrent Protection	75A _{peak} (30kW UL version) 85A _{peak} (33.3kW CE version)

8.5. CAN communication

8.5.1. CAN transceiver

An isolated CAN transceiver is implemented to communicate through a high-speed CAN with other boards.

CAN bus is expected to be terminated at each bus end with a $120\ \Omega$ resistance. Wiring should be selected to have an intrinsic impedance of the twisted that match this $120\ \Omega$. By default, MPU-R2 does not include any $120\ \Omega$ resistor to avoid overloading the bus.

External $120\ \Omega$ bus termination could be needed to ensure proper work.

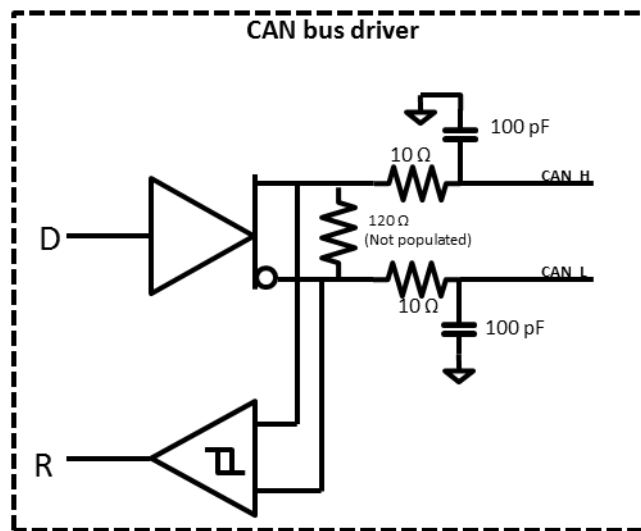

Figure 23: CAN transceiver simplified diagram

8.5.2. CAN configuration and dictionary

CAN baud rate

CAN 2.0A cadenced at 500kbit/s with little endian byte order.

Node ID

See section **Address selector and Charge Permission**.

Heartbeat frame

MPU-R2 automatically transmits its communication state at regular intervals as evidence of its communication ability. This frame is sent every 1 sec.

MPU-R2 also consumes the heartbeat of its master (expected to have the node ID 0x1). So, the master shall emit every 1 second a heartbeat frame with an *operational* status. If this frame is not received by the MPU, the charge will be stopped and the MPU will get into fault state.

For example, if the CAN ID is x56:

Node	Frame ID	ID offset	DLC	Byte 0
MPU-R2	x756	x700	1	MPU-R2 Status
Master	x701	x700	1	MasterStatus

- Frame ID = Node ID + ID offset
- Status = 0 at bootup (1 frame with 0 to be sent at boot)
- Status = 5 when node communication stack is operational (to be sent periodically)
- Status = 4 when node communication stack is stopped (to be sent periodically)
- Status = 127 when node communication stack is pre-operational (to be sent periodically)

Sync frame

To trigger synchronous sending of frame, MPU-R2 is sensible to a SYNC message.

Frame ID	DLC
x80	0

Receive Process Data Object (RPDO)

The RPDO frame is the control frame. MPU state and setpoints are sent by the master.

For example, if the CAN ID is x56:

Frame ID	ID offset	DLC	Byte 0	Byte 1	Byte 2	Byte 3	Byte 4
x256	x200	7	StateRequestWord	itfc_output_current_setpoint	itfc_output_voltage_setpoint		

Byte 5	Byte 6	Byte 7
itfc_input_grid_max_current		

Transmit Process Data Object (TPDO)

Frames sent from MPU to master

Table 8: Frame sent after having received SYNC on MPU (CAN ID=86)

Frame ID	ID offset	DLC	Byte 0	Byte 1	Byte 2	Byte 3	Byte 4	Byte 5	Byte 6	Byte 7
x1D6	x180	6	itfc current state		itfc critical fault word					
x2D6	x280	8	itfc v_grid		itfc i_grid		itfc P_grid		itfc available i batt	
x3D6	x380	8	itfc v_batt		itfc i_batt		itfc P_batt		itfc i_grid_max	
x4D6	x480	8	itfc v_batt_min	product_type	itfc v_batt_max		itfc i_batt_max		itfc P_batt_max	

- Frame ID = Node ID + ID offset
- Each TPDO is transmitted after reception of N number of Sync message. This number is defined by the transmission type parameter of the TPDO. For MPU, transmission type for TPDOs are defined in the following table

Table 9: TPDOs transmission type

TPDO number	Transmission type
TPDO1	1
TPDO2	1
TPDO3	1
TPDO4	1

Emergency frame

Emergency frame is sent asynchronously by MPU in case of default.

Frame ID	ID offset	DLC	Byte 0	Byte 1	Byte 2	Byte 3	Byte 4	Byte 5	Byte 6	Byte 7
xD6	x80	8	Error code		Error register	Unused	Data			

- Frame ID = Node ID + ID offset
- Error Code: 0xFF01 if the MPU is in Fault mode. Other Error codes due to communication stack are defined by CANopen.
- Error Register: To be ignored, if the MPU is in Fault mode
- Data: if the MPU is in Fault mode, data = CriticalFaultWord. If not, it should be ignored.

Data unit and type definition

Messages data types and units are defined in the table below

Table 10: Frame data definition

Signal	Definition	LSB value	Unit	Data type	r/w (from master point)	Frame
StateRequestWord	The request word	See Request word def (Table 12)	NA	UInt8	w	RPDO0
itfc_output_voltage_setpoint	Output voltage setpoint (battery side)	0.1	V	UInt16	w	RPDO0
itfc_output_current_setpoint	Output current setpoint (battery side)	0.01	A	UInt16	w	RPDO0
itfc_input_grid_max_current	Grid current limitation setpoint	0.01	A	UInt16	w	RPDO0
itfc_current_state	The status word	See StatusWord def (Table 11)	NA	UInt16	r	TPDO0
itfc_critical_fault_word	The fault word	See FaultWord def (Table 16)	NA	UInt32	r	TPDO0
itfc_v_grid	Grid voltage	0.1	V	UInt16	r	TPDO1
itfc_i_grid	Grid current	0.01	A	UInt16	r	TPDO1
itfc_P_grid	Grid power	1	W	UInt16	r	TPDO1
itfc_available_i_batt	Available battery side current	0.01	A	UInt16	r	TPDO1
itfc_i_grid_max	Max allowed grid current	0.01	A	UInt16	r	TPDO2
itfc_v_batt	Output voltage (battery side)	0.1	V	UInt16	r	TPDO2
itfc_i_batt	Output current (battery side)	0.01	A	UInt16	r	TPDO2
itfc_P_batt	Output power (battery side)	1	W	UInt16	r	TPDO2
itfc_v_batt_max	Max allowed output voltage	0.1	V	UInt16	r	TPDO3
itfc_i_batt_max	Max allowed output current	0.01	A	UInt16	r	TPDO3
itfc_P_batt_max	Max allowed output power	1	W	UInt16	r	TPDO3
itfc_v_batt_min	Min allowed output voltage	10	V	UInt8	r	TPDO3
product_type	Product type	1	NA	UInt8	r	TPDO3

Status word definition

Table 11: Status Word

Bit	Flag name	Flag definition
0:3	System Mode	State, see Table 12
4	SafeCFlag	Set to 1 if phase voltages are not within the static voltage range
5	FuseAmbTempDeratingFlag	Set to 1 if t temperature 1 is used in power derating
6	MagneticsTempDeratingFlag	Set to 1 if t temperature 2 is used in power derating
7	PfcMOSTempDeratingFlag	Set to 1 if t temperature 3 is used in power derating
8	CurrentRegulationFlag	Set to 1 if PU is limited by max Current
9	VoltageRegulationFlag	Set to 1 if PU is limited by max Voltage
10	ActivePowerRegulationFlag	Set to 1 if PU is limited by max Power
11	PfcOnFlag	Set to 1 if PFC is ON
12	DcdcOnFlag	Set to 1 if DCDC is ON
13	InputCurrentLimitationFlag	Set to 1 if PU is limited by input current
14	OutputLoadImpedanceLimitationFlag	Set to 1 if MPU is limited by output load impedance
15	ThermalLimitationFlag	Set to 1 if PU is limited by thermal heating

Some intermediate sub-states exist in the state machine that are also accessible through the status word. Although these sub-states are transparent to the user, they are documented on Table 13: System substates definition for completeness.

Table 12: System states definition (Request Word)

Value	Name	Definition
0	STATE_INIT	System is starting
1	STATE_STANDBY	Power is off, system waits a request
3	STATE_POWER_ON	System ready to start
4	STATE_LOCK_DSP	The ACDC waits for DCDC Standby mode status
5	STATE_CHARGE	Charge on going
6	STATE_STOPPING	Converter is stopping and power is being killed off
7	STATE_SAFE_D	Critical fault occurred, system halted in this mode until user action.
8	STATE_SAFE_C	Converter is in safeC mode

Table 13: System substates definition

Value	Name	Definition
0	SUBSTATE_INIT	System is starting
1	SUBSTATE_STANDBY	Power is off
2	SUBSTATE_PFC_PASSIVE_PRECHARGE	Precharge realys are closed, system is precharging the DC link bus
3	SUBSTATE_PFC_PASSIVE_PRECHARGE_DRIVER_ON	Passive precharged is completed, power legs pwm drivers are on
4	SUBSTATE_PFC_ACTIVE_PRECHARGE	DC link voltage and soft start condition are checked, systems starts pfc closed loop control to complete active precharge.
5	SUBSTATE_PFC_CHARGING	DCDC is ready and in charging mode
6	SUBSTATE_SAFE_C	System is stopped and remains waiting for Safe C condition clearance
7	SUBSTATE_STOPPING	System is requested to stop, power is still on
8	SUBSTATE_SAFE_D	Critical fault occured, system halted in this mode until fault clearence or STANDBY request
9	SUBSTATE_LOCK_DSP	The ACDC waits for DCDC Standby mode status
10	SUBSTATE_FAULT_ACK	Fault acknowledgement

The DCDC converter is supervised by an inner state machine that is controlled by the charger state machine. The DCDC states are presented in Table 14: DCDC states definition.

Table 14: DCDC states definition

Value	Name	Definition
0	STATE_DCDC_INIT	System is starting
1	STATE_DCDC_STANDBY	Power is off, system waits a request
2	STATE_DCDC_POWER_ON	System ready to start
3	STATE_DCDC_CHARGE	Charge on going
4	STATE_DCDC_SAFE_D	Critical fault occured, system halted in this mode until user action.
5	STATE_DCDC_STOPPING	Converter is stopping and power is being killed off
6	STATE_DCDC_LOCK_DSP	The DCDC waits a request for Standby mode
7	STATE_DCDC_FAULT_ACK	DCDC fault acknowledgement

Product type

Table 15: product type definition

Value	Product
0	MPU-R3
1	MPU-R2 (AC)

Fault Word code

In order to prevent the system from failure event which could damage product, MPU-R2 has several securities faults. These faults statuses are indicated in bit-wise word "FaultWord" defined as follow:

Table 16: Fault word definition

Bit	Fault	Description
0	Over_current_L1	Over-current protection on phase 1
1	Over_current_L2	Over-current protection on phase 2
2	Over_current_L3	Over-current protection on phase 3
3	Over_voltage_grid	Over-voltage protection on phase 1/2/3
4	Output_relay_position	Diagnostic of the relay on dc side
5	unused	unused
6	Under_voltage_L1	Under-voltage protection on phase 1
7	Under_voltage_L2	Under-voltage protection on phase 2
8	Under_voltage_L3	Under-voltage protection on phase 3
9	OV_Regul_v_batt	DC output voltage regulation loss
10	OV_v_bus	Over-voltage protection on intermediary Bus
11	OV_v_batt	Over-voltage protection on battery
12	OV_v_batt_1	Over-voltage protection on battery voltage of DCDC 1
13	OC_i_batt	Over-current protection on battery
14	OC_i_batt_1	Over-current protection on battery current of DCDC 1
15	UV_PFC_precharge_failure	Under-voltage precharge failure
16	short_circuit_imp	Dc side impedance for short circuit detection
17	ShutT_Temp_DCDCA	Thermal shutdown on DCDC 1 mosfets
18	ShutT_Temp_DCDCB	Thermal shutdown on DCDC 2 mosfets
19	ShutT_Temp_DCDC_XFO	Thermal shutdown on DCDC transformers
20	ShutT_Temp_DCDC_Diode	Thermal shutdown on DCDC diodes
21	ShutT_TempPFC	Thermal shutdown on PFC mosfets
22	ShutT_Temp_Amb	Thermal shutdown on ambient temperature
23	unused	unused
24	UVP_Aux_LV	Under-voltage protection on LV auxiliary power supply
25	emergency_shutdown	Emergency shutdown input triggered
26	device_timeout	No reception of master heartbeat frame for more than timeout period
27	dcdc_pfc_com_loss	Communication loss between PFC and DCDC
28	dcdc_pfc_com_errors	Communication errors between PFC and DCDC
29	chargeP	No charge permission input
30	address_selection	No valid address selected
31	discharge_failure	Output capacitor discharge failure

9. Mechanical specifications

MPU-R2 30kW is packaged in a 2U standard 19" rack.

The total length from front to rear panel is 517.6mm (excluding handles).

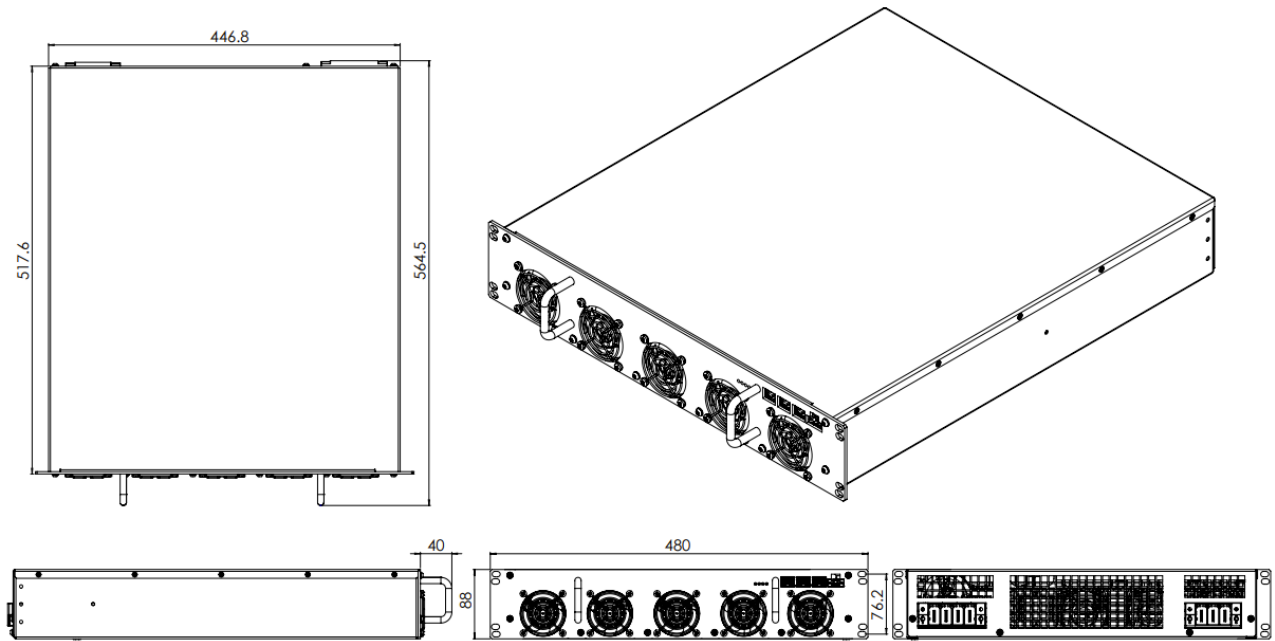

Figure 24: MPU-R2 assembly drawing.

10. Maintenance

It is forbidden to open the product.

10.1. Cleaning

Use a soft cloth for cleaning the device. Do not use cleaning agent.

Internal dust could be removed with vacuum cleaner or dry air cleaning.

10.2. Cooling fan

Cooling fans are internally controlled. Do not obstruct apertures on the case side.

10.3. Fuse replacement

DC side is protected by an adequate fuse.

Fuse replacement is only allowed by WATT & WELL qualified personnel. Return product to factory for replacement.

11. Ordering information

11.1. Product Reference

	Status	P	AC side	DC side	Other
MPU-R2-920-100-FD	In production	33.3 kW	3Φ	920V, 100A	x
MPU-R2-920-100-FD-UL	In production	30 kW	3Φ	920V, 100A	UL2202 certified (E537398)

11.2. Product accessories

<p><u>WA048 – Set of mating connectors for MPU-R2</u> AC side, DC side and LV side. Unwired</p> <ul style="list-style-type: none"> • LV Side: MSTB 2,5/ 2-STF-5,08 - 1777989 • AC side: PC 35 HC/ 4-STF-15,00 - 1762615 • DC side: PC 35 HC/ 3-STF-15,00 - 1762602 	
<p><u>WA050 – Pre-wired AC harness 63A for MPU-R2</u> with 10mm² color-coded wire and IEC 60309 63A plug (3P+PE)</p> <p>Cable length: 2.5m</p>	
<p><u>WA051 – Pre-wired DC harness for MPU-R2</u> with 25mm² color-coded wire and M6 lug termination</p> <p>Cable length: 2.5m</p>	
<p><u>WA016 – Pre-wired LV harness</u> With color-coded 4mm insulated banana plug</p> <p>Cable length: 2.5m</p>	
<p><u>WA007 – CAN bus adaptor from RJ45 to DB9</u> including 120 Ω termination resistance</p>	

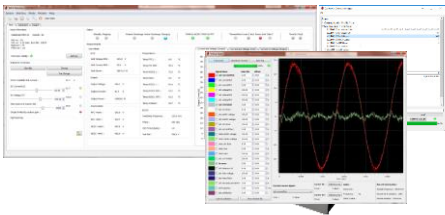
<p><u>WA009 – USB to CAN transceiver (Kvaser)</u> Compatible with MPU Monitor</p>	
<p><u>WA049 – MPU monitor license (USB license dongle)</u> A Windows based GUI (Graphical User Interface) for easy access to measurements, monitoring and configuration parameters. It can be used to control MPU-R2 as a PC based master or to speed-up integration of a dedicated system master.</p>	

11.3. Related products

EVI is a dual standard Supply Equipment Communication Controller (SECC) with all required signals for CCS2 /Combo and CHAdeMO communications.

Main features:

- CCS protocol compatible
 - ISO15118-2 and ISO15118-20
- CHAdeMO compatible (via Extension board)
 - Version 0.9 & 1.2
- Insulation Measurement Device according to IEC61557-8
- High voltage 920V charging.
- OCPP 1.6 and soon OCPP 2.0.1
- Smart Charging & V2G charging modes
- Cable temperature measurement
- Crypto ready with Secure Element embedded



EVIX – EVI Extension board:

An optional extension board (EVIX) can add additional functions such as:

- EVIX-AD6: Addressing of 6 power units
- EVIX-AD14: Addressing of 14 power units (ADDR 80 to 93)
- EVIX-AD6-CHA: CHAdeMO HW interface & Addressing 6 power units
- EVIX-IO: Peripheral extension board

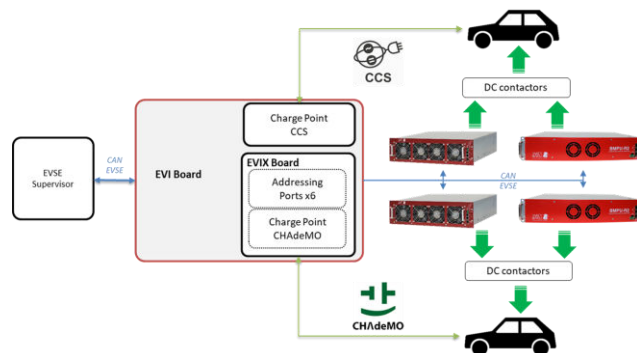

Figure 25: EVI & EVIX integration on EVSE environment

Other customization options available under request

contact@wattandwell.com

+33 1 75 5 11 50