

**100 kW Modular Power Unit for EVSE**



**OVERVIEW**

**Pinnacle** is a 100kW modular power supply for EVSE systems supplied by DC grid or stationary batteries.

It features a modular design capable of parallel operation.

**VERSIONS**

	EV SIDE		
	P	U	I
<b>MPU-R2-DC-1500-220</b>	<b>100kW</b>	<b>1500V</b>	<b>220A</b>

**FEATURES**

- Input DC connection with a range of 500VDC to 1500VDC.
- Reinforced galvanic isolation between input and output.
- Compatible with the following DC charging systems: MCS, CCS1, CCS2, NACS/J2400.
- Liquid cooling.
- 19" rack, 2U.
- One CANopen compatible digital bus and one ethernet Modbus TCP, with advanced control, monitoring, and logging capabilities.
- Integrated protections including charge switches, OCP, OTP, OVP and UVLO.
- Pre-charge circuits.

**BLOCK DIAGRAM**

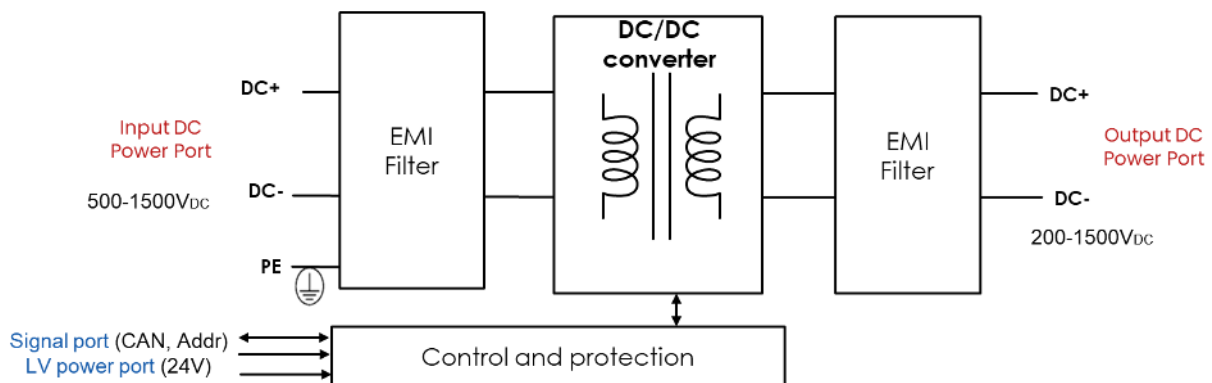

Product datasheet. The given values are susceptible to change without prior notice.

**Important note: this datasheet contains advanced information about an unreleased product. Values are susceptible to change in significant ways without prior notice (preliminary design)**



**WARNING**

This equipment operates at voltages and currents that can result in electrical shock, fire hazard and/or personal injury if not properly handled or applied. Equipment must be used with necessary caution and appropriate safeguards employed to avoid personal injury or property damage.

This board must be used only by qualified engineers and technicians familiar with risks associated with handling high voltage electrical and mechanical components, systems, and subsystems.

**Table of Contents**

<b>1.</b>	<b>Safety instructions .....</b>	<b>5</b>
1.1.	Caution .....	5
1.2.	Installation.....	5
1.3.	Input rating.....	5
1.4.	Live circuits .....	5
1.5.	Hot surface .....	6
1.6.	Marking.....	6
1.7.	Maintenance .....	6
1.8.	Safety related functions.....	6
1.9.	Parts substitution and modifications .....	7
1.10.	Environmental condition.....	7
1.11.	Normative compliance.....	7
<b>2.</b>	<b>Absolute maximum ratings .....</b>	<b>9</b>
<b>3.</b>	<b>Electrical Characteristics .....</b>	<b>9</b>
3.1.	Safe Operating Area .....	10
3.2.	Reliability .....	11
3.3.	Typical efficiency.....	11
3.4.	Output power derating.....	11
<b>4.</b>	<b>Installation .....</b>	<b>12</b>
4.1.	Mechanical installation .....	13
4.1.1.	<i>Handling.....</i>	13
4.1.2.	<i>Mounting .....</i>	13
4.1.3.	<i>Cooling system .....</i>	13
4.2.	Electrical installation .....	13
4.2.1.	<i>Legal installation .....</i>	13
4.2.2.	<i>Safety Notice .....</i>	13
4.2.3.	<i>Protective earth .....</i>	14
4.2.4.	<i>Input.....</i>	14
4.2.5.	<i>LV DC input .....</i>	14
4.2.6.	<i>DC Output.....</i>	14
4.2.7.	<i>EMI requirements .....</i>	14
4.2.8.	<i>Series operation .....</i>	15
4.2.9.	<i>Disposal .....</i>	15
<b>5.</b>	<b>Hardware specification .....</b>	<b>15</b>
5.1.	Theory of operation .....	15
5.2.	Interfaces and supply cables.....	15
5.2.1.	<i>Low voltage connector.....</i>	15
5.2.2.	<i>Grid side connector .....</i>	16
5.2.3.	<i>Output side connector .....</i>	16
5.2.4.	<i>Liquid cooling connector.....</i>	16
5.2.5.	<i>COM connectors.....</i>	16
5.2.6.	<i>Emergency Shutdown .....</i>	18
5.2.7.	<i>Address selector.....</i>	18
5.2.8.	<i>Protective Earth .....</i>	21
<b>6.</b>	<b>Mechanical specifications .....</b>	<b>21</b>
<b>7.</b>	<b>Maintenance .....</b>	<b>21</b>
7.1.	Cleaning.....	21
7.2.	Liquid cooling.....	21
<b>8.</b>	<b>Ordering information .....</b>	<b>22</b>
8.1.	Product Reference .....	22
8.2.	Product accessories.....	22

8.3. Related products.....23

# 1. Safety instructions

## IMPORTANT SAFETY INSTRUCTIONS

SAVE THESE INSTRUCTIONS – This manual contains important instructions for **Pinnacle** model that shall be followed during installation, operation and maintenance of the unit.

### 1.1. Caution

The following safety instruction must be observed during all phases of operation, service and repair of this equipment. Failure to comply with the safety precautions or warnings in this documentation violates safety standards of design, manufacture and intended use of this equipment and may impair the built-in protections within. WATT & WELL shall not be liable for users to comply with these requirements.

### 1.2. Installation

**Pinnacle** device must be installed following installation chapter.

This product is a safety **Class 1** instrument. To minimize shock hazard, the instrument chassis must be connected to the EVSE frame which is in turn connected to earth ground.

The protective earth terminal must be connected to the safety electrical ground before another connection is made. Any interruption of the protective ground conductor, or disconnection of the protective earth terminal will cause a potential shock hazard that might cause personal injury.

**Pinnacle** device is designed to be accessible only for trained staff operators in **restricted access locations**.

### 1.3. Input rating

CAUTION – To reduce the risk of fire, connect only to a circuit provided with 100 amperes maximum branch circuit overcurrent protection in accordance with the National Electrical Code, ANSI/NFPA 70.

Do not use power supplies which exceed the input voltage rating of this instrument. The electrical rating of this instrument is given into the chapter 3 of this document.

### 1.4. Live circuits



Operating personnel are not allowed to open the case of this equipment. Internal adjustment or component replacement is not allowed by non-WATT & WELL qualified personnel. Never replace components with cable connected to this instrument. To avoid injuries, always disconnect power and remove external voltage sources before touching components.

### 1.5. Hot surface

Surface of the product could be hot during and after operation.

To reduce the risk of burns - Use adequate protection before touching the device.

### 1.6. Marking

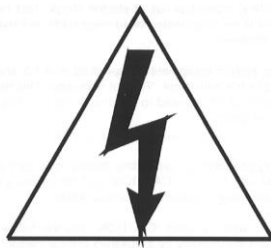
Symbol	English	French
	Input DC voltage	Tension d'entrée continue
	Grounding	Prise de Terre
	CAUTION - Risk of electric shocks	Attention - Risque de choc électrique

### 1.7. Maintenance

Capacitors inside the unit store hazardous energy. Do not remove the cover until 5 minutes after disconnecting all sources of supply.

### 1.8. Safety related functions

All safety related mechanisms and functions are implemented by hardware. The software does not provide or perform safety-related functions.

## 1.9. Parts substitution and modifications

Parts substitutions and modifications are allowed by authorized WATT & WELL service personnel only.

For repairs or modification, the unit must be returned to WATT & WELL's After Sale Service. Contact After Sale Service ([aftersales@wattandwell.com](mailto:aftersales@wattandwell.com)) to obtain a return merchandise authorization (RMA) number.

WATT & WELL  
After Sale Service  
121 Rue Louis Lumière  
84120 PERTUIS  
France

## 1.10. Environmental condition

**Pinnacle** device safety approval applies to the following operating conditions:

- Integrated into EVSE system (in a 19" cabinet or a custom build enclosure)
- Maximum relative humidity : 95% at 40°C non-condensing
- Altitude : up to 4000m
- Pollution degree : 2<sup>1</sup>
- Overvoltage category : II on the input side
- IP degree of enclosure : IP4X



Protective ground conductor terminal

The charging station where **Pinnacle** will be installed should meet the requirements of environmental protection as defined in IEC 61851-1:2019.

The IP degree needs to reach IP44 or above for outdoor use or IP21 for indoor use.

Avoid using the charger in the offshore environment near the sea or near a pollution source or in a corrosive and damaging environment. If you need to use it in the above environment, the protection level of the station needs to reach IP65, otherwise it may lead to the failure of **Pinnacle**. This damage caused will not be covered by the warranty.

## 1.11. Normative compliance

**Pinnacle** meets the intent of directives:

- Low Voltage: 2014/35/UE
- CEM 2014/30/UE
- RoHS: 2011/65/UE



<sup>1</sup> Attention should be paid to avoid ingress of water, metallic or conductive particles, dust or corrosive atmospheric that may cause early failures of equipment.

- WEEE: 2012/19/EU

The compliance will be demonstrated to the normative reference:

Normative	Name	Note
NF EN IEC 61000-6-2	Electromagnetic compatibility (EMC) Part 6-2: Generic standards Immunity for industrial environments	
NF EN IEC 61000-6-3	Electromagnetic compatibility (EMC) Part 6-3: Generic standards – Emission standard for equipment in residential environments	
IEC 61000-4-28	Electromagnetic compatibility (EMC) – Part 4-28: Testing and measurement techniques – Variation of power frequency, immunity test	Criterion A
IEC 61000-4-6:2013	Conducted RF Fields	
IEC 61000-4-4:2012	Electrical fast transient/burst immunity test Input power line	±2kV
IEC 61000-4-5:2014	Surge immunity test DC power line	±2kV common mode ±1kV differential mode
IEC 61000-4-3:2006 /AMD1:2007/AMD2:2010	Radiated, radiofrequency, electromagnetic field immunity test	Industrial Level
IEC 61000-4-2:2008	Electrostatic discharge immunity test	±4kV contact ±8kV air discharges
CISPR 16-2- 1:2014/AMD1:2017	Conducted emission	Class B
CISPR 16-2-3:2016	Radiated emission	Class B

Please also note that **Pinnacle** is designed to be compatible with the following norms:

Normative	Name	Note
IEC 61851-1:2019 (ed 3.0)	Electric vehicle conductive charging system Part 1: General requirements	
IEC 61851-23:2023	Electric vehicle conductive charging system Part 23: DC electric vehicle charging station	
IEC 61851-21-2	Electric vehicle conductive charging system - Part 21-2: Electric vehicle requirements for conductive connection to an AC/DC supply - EMC requirements for off board electric vehicle charging systems	Limits for DC power input and CPT ports

However, it is the user's responsibility to ensure that **Pinnacle** is installed and used in compliance with all local country laws and regulations. The product will be marked CE starting from version 1.0.

## 2. Absolute maximum ratings

**Table 1: Absolute maximum ratings**

Parameter	Condition	Min	Max	Units
LV Input Voltage		0	29	V
Output DC voltage		0	1500	V
Input DC voltage		0	1500	V
Operating Temperature		-30	70	°C
Long term storage Temperature		-30	70	°C
Temperature change rate			5	°C/min
DC grid (DC+ grid or DC- grid) to PE			±1500	V
DC output (DC+ out or DC- out) to PE			±1500	V

**Recommended maximum coolant temperature is 50°C**, beyond 50°C, linear derating on power output is applied.

## 3. Electrical Characteristics

All specifications are given for coolant temperature up to 50°C unless otherwise noted.

**Table 2: Electrical characteristics**

Parameter	Condition	Value			Units
		Min	Typ	Max	
<b>DC gride side</b>					
Input voltage		500		1500 <sup>1</sup>	V <sub>DC</sub>
Input current		0		100	A <sub>DC</sub>
Inrush current				30	A <sub>pk</sub>
Current measurement accuracy	@100A			3	%
Voltage measurement accuracy	@1500V			3	%
<b>EV side</b>					
Output voltage		200		1500	V <sub>DC</sub>
Power				100	kW
Maximum power variation (SW programmable)				30	kW/s
Current				220	A <sub>DC</sub>
Voltage measurement accuracy	@1500V			1	%
Current measurement accuracy	@220A			1.5	%

<b>Parallel operation</b>					
Number of parallel modules				20	
<b>CAN communication</b>					
CAN baud rate			500		kbps
CAN common mode range <sup>2</sup>		-7		7	V
<b>Digital Inputs</b>					
Positive going input current (Charge permission, Address, EMS)		2		10	mA
Negative going input current (Charge permission, Address, EMS)				0.1	mA
Maximum reverse voltage				5.5	V
<b>LV input</b>					
Supply voltage		19	24	29	V
Input current standby			0.2		A
Input current operation			1.5		A
Input current start-up (inrush)	@24V input during 1ms			10	A
Under Voltage Shutdown (programmable)				19	V
Over Voltage Shutdown (programmable)				27	V
Power consumption			5 <sup>3</sup>	35	W
<b>Insulation - Dielectric strength</b>					
DC Input to DC output	1 min		6400		V <sub>DC</sub>
DC Input to case (PE)	1 min		3200		V <sub>DC</sub>
DC Output to case (PE)	1 min		3200		V <sub>DC</sub>
Y-capacitor input to PE				80	nF
Y-capacitor output to PE				80	nF

### 3.1. Safe Operating Area

**Pinnacle** automatically adjusts its operation to the typical operating zone of an EV battery and can charge 400V nominal EV batteries with a voltage range of [250V; 550V], 800V nominal EV batteries with a voltage range of [500V; 920V] and MCS at higher voltages up to 1250V.

**Pinnacle** can reconfigure between different configurations in less than 3sec.

The overall Safe Operating Area (SOA) is shown in Figure 1.

<sup>1</sup>Power conversion is off when DC grid voltage is above 1500V

<sup>2</sup> CAN common mode; CAN\_H and CAN\_L versus CAN\_GND

<sup>3</sup> Standby mode operation

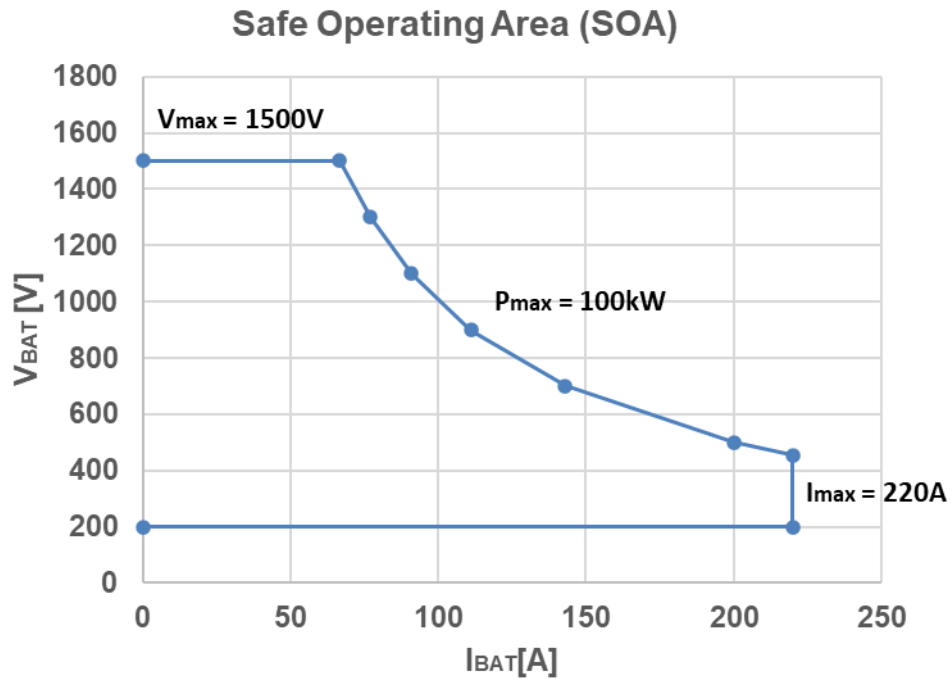

**Figure 1: Battery Side Safe Operating Area @1300V DC grid**

### 3.2. Reliability

**Table 3: Reliability characteristics**

Parameter	Condition	Value			Units
		Min	Typ	Max	
MTBF	Coolant temperature 40°C		500,000		hours

### 3.3. Typical efficiency

**Pinnacle** is based on highly efficient full SiC (Silicon Carbide) technology. Peak efficiency reaches 98.5% and efficiency is consistently above 97% for a wide range of battery voltage and current.

### 3.4. Output power derating

**Pinnacle** is sized for 103 kW (Input side power) at 1030V<sub>DC</sub>

- Below 1030V input voltage, power is limited by max current 100 A<sub>DC</sub>
- Above 1030V input voltage, power can be kept constant (103kW)

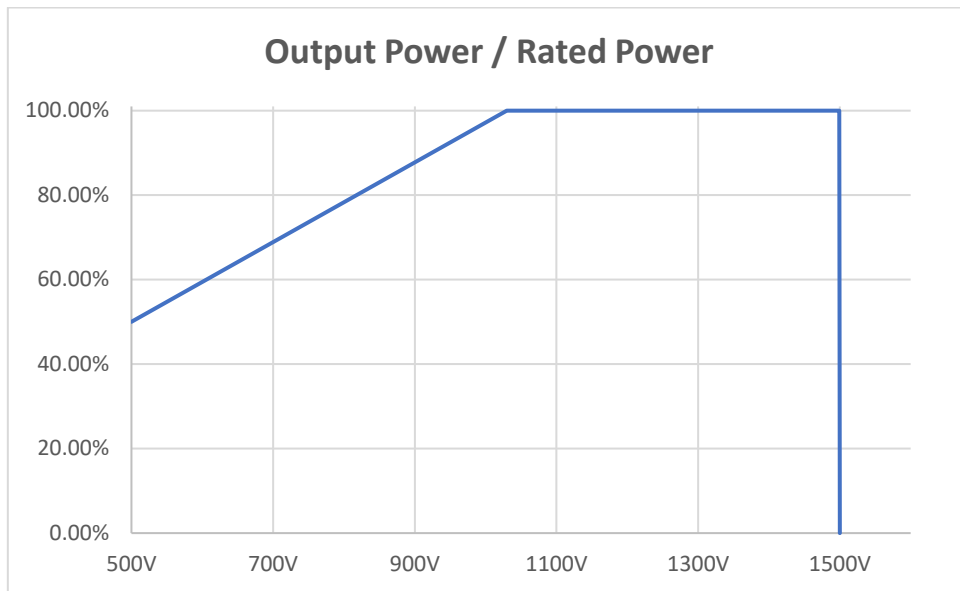

**Figure 2: Output power vs DC input voltage**

In addition, the output power is limited based on the output voltage:

- Below 455V output voltage, power is limited by max current 220 A<sub>DC</sub>
- Above 455V output voltage, power can be kept constant (100kW)

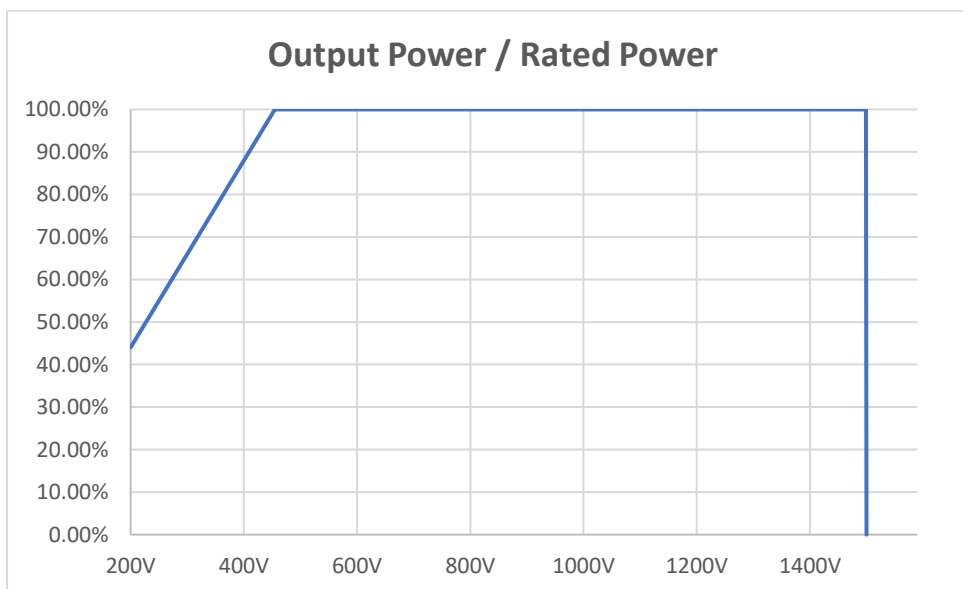

**Figure 3: Output power vs DC output voltage**

## 4. Installation

The unit must be properly assembled in accordance with the assembly instructions before it is used.

Do not use or install **Pinnacle** product in case of visible physical damage.

## 4.1. Mechanical installation

### 4.1.1. Handling

**Pinnacle** product has a weight of about 30 Kg. For correct handling, follow instruction below:

- The product must be handled flatly.
- For operator safety use personal protective equipment.
- Do not stack units (each unit should be self-supported and secured with the front and rear brackets)

### 4.1.2. Mounting

**Pinnacle** can be mounted on standard 19" cabinets.

Note that **Pinnacle** is a heavy instrument and requires the cabinet to be equipped with slides or rails that support the chassis along the depth.

### 4.1.3. Cooling system

**Pinnacle** is liquid cooled. The following table shows the cooling system parameters.

**Table 4: Cooling system parameters**

Parameter	Value
Liquid Flow	5 to 10L/min
Water pressure drop	<0.5 bar @10LPM
Maximum inlet pressure	2.5 bar
Coolant	Demineralized water, Water plus ethylene glycol
Inlet temperature	-40 to 70°C (Power derating @50°C)

## 4.2. Electrical installation

### 4.2.1. Legal installation

Electrical installation shall comply with international standards such as IEC or the requirements in national standards of each country.

### 4.2.2. Safety Notice

Never invert the polarity of the connector. Never force to place a connector. Use only approved manufacturer parts for electrical or mechanical connection.

It is strongly recommended to fix the cables to avoid any stress on the connection. All high-power connectors must be screwed up to avoid any disconnection.

Be careful if other devices are connected, there is a risk of electrical charge transfer.

It is forbidden to open the cover. Only WATT & WELL approved personnel are allowed to do maintenance operations. Waiting time after complete suppression of input voltage before opening the device should be respected.

### 4.2.3. Protective earth

**Pinnacle** should be referenced to the EVSE frame which is in turn is connected to earth ground. Any interruption of the protective ground conductor, or disconnection of the protective earth terminal will cause a potential shock hazard that might cause personal injury or death. Protective earth connection is made through earth connection point (threaded stud with nut).

Use the protective earth terminal with minimal characteristics:

Wire section (minimal): 16 mm<sup>2</sup>

In addition, all parts of the chassis where **Pinnacle** is to be installed (i.e., the 19" cabinet) need to be grounded. An electrical connection to "G" through mechanical parts must be done.

### 4.2.4. Input

DC grid is defined as input DC+ and DC-.

**Pinnacle** product must be protected against short circuit, overload protection and earth leakage current protection with external devices.

### 4.2.5. LV DC input

LV input must be connected to 24Vdc bus. This input must be protected with a rapid fuse 20A rating.

This cable must be shorter than 3m.

### 4.2.6. DC Output

DC output is galvanically isolated from protective earth. This output must be protected with a rapid fuse.

This cable must be shorter than 30 m.

### 4.2.7. EMI requirements

Converters are designed to be compliant with IEC 61000-6-1/2/3/4 standards.

- EMI emissions
  - Conducted emissions: class B
  - Radiated emissions class B
- EMI immunity
  - IEC EN 61000-6-2: Immunity standard for industrial environments
  - IEC EN 61000-6-1: Immunity standard for residential, commercial and light-industrial environments

However, Integrator is responsible to use best practice for final system to avoid high EMI emissions.

#### 4.2.8. Series operation

- Grid side:
  - Series operations of **Pinnacle** is not allowed.
- EV side:
  - Series operations of **Pinnacle** is not allowed.

#### 4.2.9. Disposal



- (Mandatory application within the European Union)
- Do not dispose of electronic tools tighter with household waste material. In accordance with WEEE European Directive (2012/19/UE), Electric material that has reached the end of their life must be collected separately and return to an environmentally compatible recycling facility. Please contact WATT & WELL for any questions about WEEE

## 5. Hardware specification

### 5.1. Theory of operation

**Pinnacle** consist of DC/DC converter that performs galvanic isolation and DC side regulation. It is based on a full SiC resonant topology.

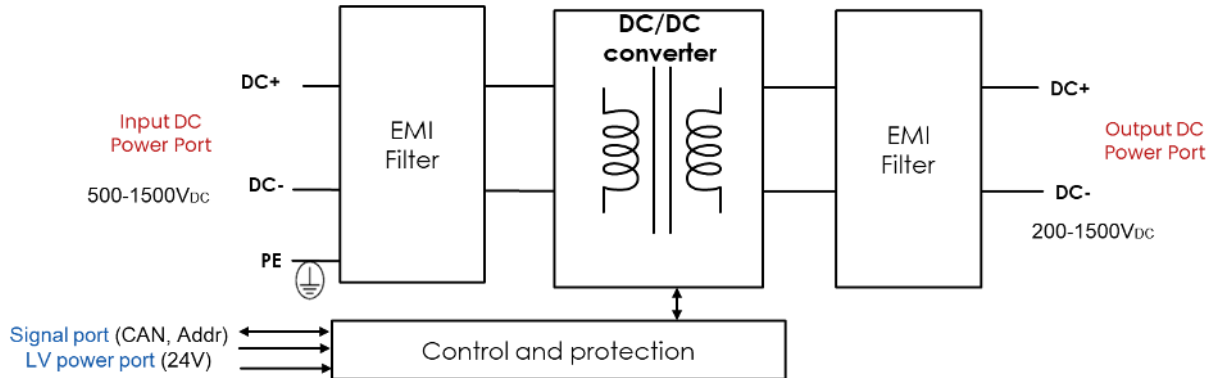

**Figure 4: Pinnacle 100 kW high level synoptic**

### 5.2. Interfaces and supply cables

Please note that the supply cables of the converter shall be chosen to have an ampacity based on Table 310-16 of the National Electrical Code, ANSI/NFPA 70 of no less than 125 percent of the maximum current that the circuit carries during rated conditions; and that a wiring terminal are provided with a pressure terminal connector that is securely held by a screw.

Please use an ordinary tool for securing all conductors.

#### 5.2.1. Low voltage connector

Located on the front panel. Cable connected to these ports must be less than 3m long. The LV connector is used to power the fans and control the converter independently.

Connector Reference (converter side):

- Phoenix Contact MSTB 2,5/ 2-GF-5,08 1776508 (UL approval 300V/15A)
- TIELEE: TLPHW-200R-02P-G12 (UL approval 300V/16A)

Recommended matting connectors (wire harness side):

Side	Connector	Manufacturer	Wire	Ferrule	Crimping tool
LV	MSTB 2,5/ 2-STF-5,08 – 1777989 (Screw terminal)	Phoenix contact	1 mm <sup>2</sup>	A 1-6 Ref 3200247	Phoenix contact CRIMPFOX 6 Ref 1212034
	TLPSW-200V-02P-G12S	TIELEE	1 mm <sup>2</sup>	A 1-6 Ref 3200247	

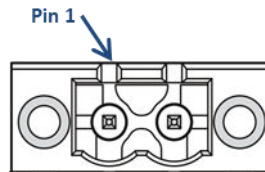

**Figure 5: Low voltage connector**

PIN	FUNCTION	DESCRIPTION	Preferred wiring color
1	LV_IN-	Low Voltage supply return (0V typ)	<b>Black</b>
2	LV_IN+	Low Voltage supply (24V typ)	<b>Red</b>

### 5.2.2. Grid side connector

Located on the front panel.

Degson high protection connectors 1500VDC 120A 25mm<sup>2</sup>: ESS-120A-25-B-OR-00 and ESS-120A-25-B-BK-00

### 5.2.3. Output side connector

Located on the front panel.

Degson high protection connectors 1500VDC 250A 70mm<sup>2</sup>: ESS-250A-70-B-OR-03 and ESS-250A-70-B-BK-02

### 5.2.4. Liquid cooling connector

A standard 1/4" cold plate connector located on the front panel.

An optional Dry Break 1/4" connector can be used.

### 5.2.5. COM connectors

### 5.2.5.1. CAN COM connector

**Pinnacle** features one galvanically isolated CAN bus for digital communications with other boards.

The CAN COM connector is an RJ45 connector. Cable connected to these ports must be less than 3m long.

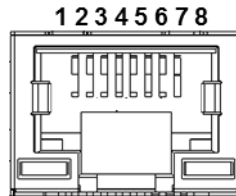

**Figure 6 : CAN COM connector front view**

**Table 5 – CAN COM connector pinout**

PIN	FUNCTION	DESCRIPTION
1	CAN H	CAN differential +
2	CAN L	CAN differential -
3	GND_ISO	Ground reference for CAN
4	EM_SHUT_RTN	Emergency Shutdown return line (negative)
5	EM_SHUT	Emergency Shutdown (positive)
6	NC	Not Connected
7	GND_ISO	Ground reference for CAN
8	ES_R/W	Read/write pin in case of daisy chained power units <b>(Mandatory to keep floating)</b>

**Note on CAN bus termination:** CAN bus is expected to be terminated at each bus end with a 120 Ω resistance. Wiring should be selected to have an intrinsic impedance of the twisted that match this 120 Ω.

By default, **Pinnacle** does not include any 120 Ω resistor to avoid overloading the bus when multiple nodes are presents.

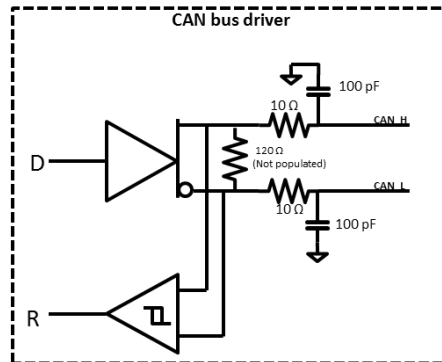

**Figure 7: CAN transceiver simplified diagram**

**Note on CAN bus shield:** Although ISO 11898-2 does not specify the wires type or the need for a shield, a shielded cable is recommended for electronically harsh environments. It is recommended to ground the shield at a single point on the dedicated shield pin of the COM connector to avoid ground loops. Also, remember that the CAN bus being isolated, the CAN\_GND should be wired between nodes.

### 5.2.5.2. Ethernet COM connector

The ethernet connector compatible with Modbus TCP is still under development.

### 5.2.6. Emergency Shutdown

The COM connector also transmits an **Emergency Shutdown** (EM\_SHUT) signal. This signal can be used to trigger an unconditional shutdown of the **Pinnacle** operation. See Table 5 for the pinout of EM\_SHUT within the COM connector.

In addition, a fast discharge circuit is enabled to discharge the internal output capacitors to a safe level ( $\ll 60V$ ) in less than 1 second.

EM\_SHUT logic is as follows:

- “floating”: Emergency Shutdown triggered (EM\_SHUT=1)
- 12V or 24V: normal operation (EM\_SHUT=0)

The simplified circuit of the EM\_SHUT is given in Figure 8.

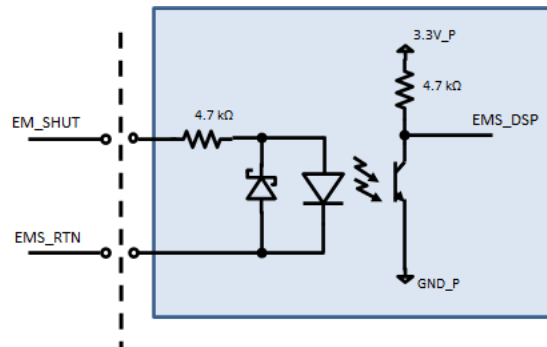

**Figure 8 DSI input circuit**

### 5.2.7. Address selector.

Each **Pinnacle** device takes its CAN **address** at boot based on the Addressing connector on the front panel.

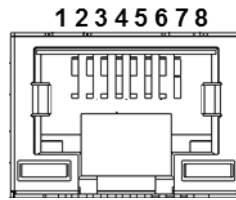

**Figure 9: Addressing connector (RJ45) front view**

**Table 6: Addressing connector pinout**

PIN	FUNCTION	DESCRIPTION
1	ADDR0	Address bit 0
2	ADDR3	Address bit 3
3	ADDR1	Address bit 1
4	ADDR4	Address bit 4
5	ADDR2	Address bit 2
6	GND_ISO	Return
7	CHARGE_P	Charge Permission
8	UNUSED	Not used

Default value of each unconnected line is logic '0'. An addressing line tied to GND\_ISO is logic '1'.

Each **Pinnacle** device takes its CAN address at boot based on the Addressing connector on the front panel.

If ADDR0= ADDR1= ADDR2= ADDR3= ADDR4=0 → CAN ID=111 (default value)

Else

CAN ID =  $80+2^0(\text{ADDR0})+2^1(\text{ADDR1})+2^2(\text{ADDR2})+2^3(\text{ADDR3})+2^4(\text{ADDR4})-1$

ADDR4	ADDR3	ADDR2	ADDR1	ADDR0	CAN ID (dec)
0	0	0	0	0	111
0	0	0	0	1	80
0	0	0	1	0	81
0	0	0	1	1	82
0	0	1	0	0	83
0	0	1	0	1	84
0	0	1	1	0	85
0	0	1	1	1	86
0	1	0	0	0	87
0	1	0	0	1	88
0	1	0	1	0	89
0	1	0	1	1	90
0	1	1	0	0	91
0	1	1	0	1	92
0	1	1	1	0	93

0	1	1	1	1	94
1	0	0	0	0	95
1	0	0	0	1	96
1	0	0	1	0	97
1	0	0	1	1	98
1	0	1	0	0	99
1	0	1	0	1	100
1	0	1	1	0	101
1	0	1	1	1	102
1	1	0	0	0	103
1	1	0	0	1	104
1	1	0	1	0	105
1	1	0	1	1	106
1	1	1	0	0	107
1	1	1	0	1	108
1	1	1	1	0	109

“**ES\_R/W**” signal: should be kept floating by user on CAN connector side. It is used to disable the charging process of all units chained together in case of a fault on one unit.

#### **LEDs**

4 LEDs on front panel indicate the status of the system

**Table 7: LED overview**

LED	COLOR	FUNCTION	Description
1	Red	Fault	Indicates a fault in the system. System stops as a result
2	Green	DC output	<b>Continuous:</b> System in charge mode
3	Green	Safe C	<b>Blinking at 5Hz:</b> Safe C mode. Input DC voltage is out of range. Output power is set off and the charger remains waiting for input DC voltage to return within acceptable range
4	Yellow or Orange	Voltage presence	<b>Slow blink:</b> Auxiliary voltage only (24V) <b>Continuous:</b> Grid voltage and Auxiliary voltage

### 5.2.8. Protective Earth

**Pinnacle** has an **earth connection** point (threaded stud with nut) on the rear panel that needs to be connected to a **protective ground** with as short a wire as possible.

## 6. Mechanical specifications

**Pinnacle** is packaged in a 2U, standard 19" rack. The total length from front to rear panel is 630mm (excluding handles).



**Figure 10: Pinnacle assembly drawing**

## 7. Maintenance

It is forbidden to open the product.

### 7.1. Cleaning

Use a soft cloth for cleaning the device. Do not use cleaning agent. Internal dust could be removed with vacuum cleaner or dry air cleaning.

### 7.2. Liquid cooling



**Pinnacle** is liquid cooled.

## 8. Ordering information

### 8.1. Product Reference

	Status	P	Grid side	EV side	Other
<b>MPU-R2-DC-1500-220</b>	Under development	100 kW	DC	1500V, 220A	x

### 8.2. Product accessories

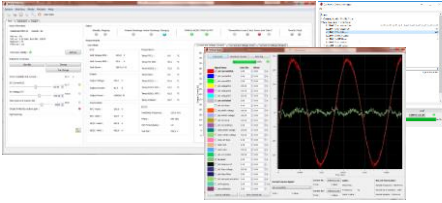
<p><b><u>WA016 – Pre-wired LV harness</u></b> With color-coded 4mm insulated banana plug</p> <p>Cable length: 1m</p>	
<p><b><u>WA007 – CAN bus adaptor from RJ45 to DB9</u></b> including 120 Ω termination resistance</p>	
<p><b><u>WA009 – USB to CAN transceiver (Kvaser)</u></b> Compatible with <b>Pinnacle</b> Monitor</p>	
<p><b><u>WA049 – MPU monitor license (USB license dongle)</u></b> A Windows based GUI (Graphical User Interface) for easy access to measurements, monitoring and configuration parameters. It can be used to control <b>Pinnacle</b> as a PC based master or to speed-up integration of a dedicated system master.</p>	

### 8.3. Related products

EVI is a dual standard Supply Equipment Communication Controller (SECC) with all required signals for CCS2 /Combo and CHAdeMO communications.

Main features:

- CCS protocol compatible
  - ISO15118-2 and ISO15118-20
- CHAdeMO compatible (via Extension board)
  - Version 0.9 & 1.2
- Insulation Measurement Device according to IEC61557-8
- High voltage 920V charging.
- OCPP 1.6 and soon OCPP 2.0.1
- Smart Charging & V2G charging modes
- Cable temperature measurement
- Crypto ready with Secure Element embedded



#### **EVIX – EVI Extension board:**

An optional extension board (EVIX) can add additional functions such as:

- EVIX-AD6: Addressing of 6 power units
- EVIX-AD14: Addressing of 14 power units
- EVIX-AD6-CHA: CHAdeMO HW interface & Addressing 6 power units
- EVIX-IO: Peripheral extension board

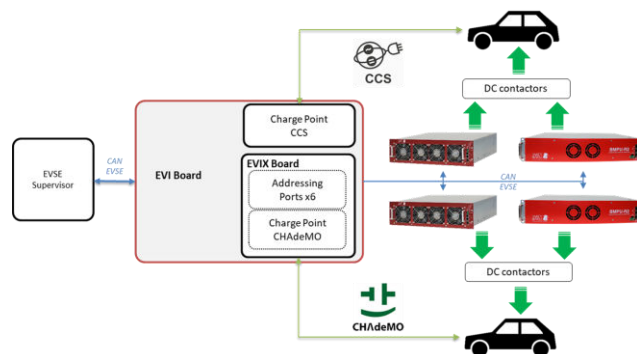

**Figure 11: EVI & EVIX integration on EVSE environment**

[contact@wattandwell.com](mailto:contact@wattandwell.com)

+33 1 75 5 11 50